

PUBLIC RELEASE

Business Requirements Specification: Medical Scheme Contributions (MSC)

**Document Classification:
Official Publication**

© South African Revenue Service

Revision History			
Date	Version	Description	Author/s
31 May 2012	0.0.1	Initial Document	SARS
05 June 2012	0.0.2	Updated Document	SARS
08 June 2012	0.0.3	Updated Document	SARS
14 June 2012	0.0.4	Updated Document	SARS
10 July 2012	0.0.5	Updated Document	SARS
10 July 2012	0.0.6	Updated Document	SARS
16 July 2012	0.0.7	Updated Document	SARS
18 July 2012	0.0.8	Updated Document	SARS
20 July 2012	0.0.9	Updated Document	SARS
02 August 2012	0.0.10	Updated Document	SARS
03 August 2012	0.0.11	Updated Document	SARS
03 August 2012	0.0.12	Updated Document	SARS
07 November 2012	0.0.13	Changed naming conventions and field length types; Increased field lengths; Added extra validation rules and source codes.	SARS
12 November 2012	0.0.14	Changed naming conventions and field length types; Increased field lengths; Added extra validation rules and source codes.	SARS
14 November 2012	V1.0.0	Published document	SARS
20 March 2013	V1.0.1	<input type="checkbox"/> Update MED unique number validation <input type="checkbox"/> Clarify file structure <input type="checkbox"/> Update file name structure <input type="checkbox"/> Update unique file id validation <input type="checkbox"/> Update channel id validation	SARS
23 December 2016	V1.0.2	Changes necessitated by <ul style="list-style-type: none"> • the need to improve matching of third party data to SARS data • alignment to other IT3 third party data BRSs • legislative requirements Changes in relation to the following: <ul style="list-style-type: none"> • Submission period indicator • Nature of person code changes • Record status changes • Passport country of issue code changes • ID/passport number mandatory based on Nature of Person • Monthly capped amount source code changes 	SARS

Revision History			
Date	Version	Description	Author/s
26 January 2017	V1.0.3	<ul style="list-style-type: none"> Referential errors fixed in the request file for fields: 168; 170; 28; 176; 35; 51; 56; 58; 59; 95; 99; 101; 102; 128; 130; 131; 162; 164; 165; 166 Referential errors fixed in response file for fields: 13; 24 Formatting of table in section 1 Align Data Type of Field 21 in response file Numbering of Appendices 	SARS

Table of Contents

1.	DEFINITIONS AND ACRONYMS.....	5
2.	INTRODUCTION.....	7
3.	CONCEPTUAL DESIGN.....	8
4.	DATA VALIDATIONS TO BE PERFORMED	9
5.	GENERAL RULES FOR IMPORT FILE STRUCTURES.....	10
6.	FILE LAYOUTS	13
6.1	FILE LAYOUT: 1. MEDICAL SCHEME CONTRIBUTIONS DATA SUBMISSION	14
6.2	FILE LAYOUT: 2. RESPONSE.....	84
7.	REFERENCE TABLES.....	94
7.1	APPENDIX A: MEDICAL SCHEME CONTRIBUTIONS SOURCE CODES TABLE	94
7.2	APPENDIX B: CODES FOR THE COUNTRY THAT ISSUED THE PASSPORT	95
7.3	APPENDIX C: IDENTIFICATION TYPE CODE TABLE	98
7.4	APPENDIX D: FILE RESPONSE CODES	98
7.5	APPENDIX E: RESPONSE CODES	99
7.6	APPENDIX F: NATURE OF PERSON	99
7.7	APPENDIX G – COMPANY REGISTRATION NUMBER VALIDATION	99
7.8	APPENDIX H: TAX REFERENCE NUMBER (MODULUS 10 VALIDATION).....	100
7.9	APPENDIX I: SOUTH AFRICAN IDENTIFICATION NUMBER.....	101
7.10	APPENDIX J: MD5 CALCULATION (FILE HASH TOTAL)	102

1. DEFINITIONS AND ACRONYMS

The following definitions and acronyms have been defined to provide assistance in identifying the meaning of SARS's terminology.

Term	Description
Alpha (A)	Alphabet A until Z only Upper Case and Lower Case
Alphanumeric (AN)	Alphabet A until Z Upper Case and Lower Case Characters Numbers 0 to 9 and a Decimal Point
CCYMM	Century-Year-Month
CCYMMDD	Century-Year-Month-Day
Conditional Fields	Fields that must be completed subject to defined conditions, e.g. mandatory if related fields have been completed
Delimited file	Pipe separated values will be used as the delimited file type
e.g.	exempli gratia (or for example)
Free Text (FT)	<p>Free text includes the following:</p> <ul style="list-style-type: none"> ○ Alphabet A until Z ○ Upper and Lower Case Characters ○ Number 0 to 9 ○ Dash (-) ○ Space () ○ Inverted Commas ("") ○ Back slash(\) ○ Forward slash (/) ○ Question Mark (?) ○ At sign (@) ○ Ampersand (&) ○ Dollar sign (\$) ○ Exclamation Mark (!) ○ Hash (#) ○ Plus (+) ○ Equals (=) ○ Semi colon (;) ○ Colon (:) ○ Comma (,) ○ Apostrophe (') ○ Left and Right Brackets (()) ○ Full Stop (.) ○ Characters such as ê, ë. <p>All special characters are allowed, however for XML development purposes the following standard must be adhered to: ISO-8859-1 encoding or informally referred to as Latin-1. The definition of this standard can be found on: http://en.wikipedia.org/wiki/ISO/IEC_8859-1</p>
ID	Identifier
Mandatory Fields	Fields that must be completed as a rule as opposed to being optional
NoP	Nature of Person
Numeric (N)	Numbers from 0 to 9, a decimal point and negative (-) sign.
Optional Fields	Fields that can be completed based on applicability and availability. These fields are not mandatory.

Term	Description
SARS	South African Revenue Service
XML	Extensible Mark-up Language
Submission tax year/financial year/current tax year	Refers to year of assessment
Member	Refers to Policy Holder
Members that resigned	Refers to members that retired, policy paid up or cancelled
Membership number	Refers to policy number of policy holder
Membership commencement date	Refers to policy commencement date

2. INTRODUCTION

The submission of Medical Scheme Contribution data to SARS is currently done using the File Transfer Protocol technology as a channel of submission. Due to the limitations on this technology and additional administrative burdens placed on 3rd party data submitters, SARS is implementing the Connect: Direct technology for the submission of bulk data using the Direct Data Flow Channel.

This document describes the interface between the South African Revenue Service (SARS) and a system reporting on 3rd party data extracts which are required to be submitted annually for Medical Scheme Contributions data.

Until further notice, the channels that will be available to submit Medical Scheme Contributions data to SARS will be via Connect: Direct, eFiling and [Secured File Gateway – HTTPS](#).

The main changes necessitating the update of the existing BRS were as a result of the following;

- the need to improve the integrity of the data for the purposes of matching third party data to the data on the SARS systems
- alignment to other IT3 third party data BRSs
- Legislative requirements.

Please note that the older changes already published were highlighted in green with the new changes highlighted turquoise in this document.

3. CONCEPTUAL DESIGN

Principal Member data can be captured and maintained in the organisation's proprietary system. The submitting entity will be able to generate a file containing all Principal Members' data and submit this file to SARS.

This file can be submitted using the Direct Data Flow channel. The submission will be validated and verified on SARS side before being deemed accepted.

The conceptual design is depicted in Figure 1 below.

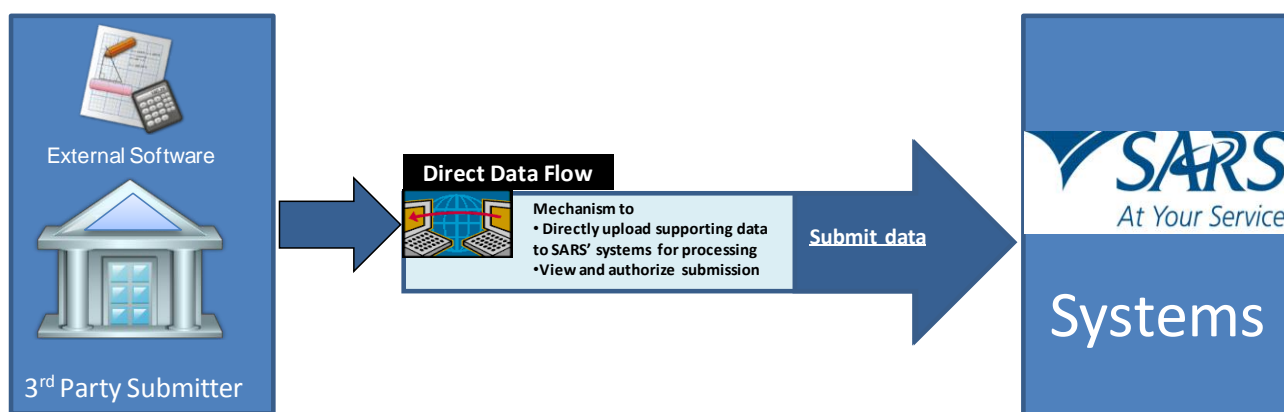

Figure 1: Conceptual design

STEP 1: Compiled data may be submitted to SARS via Connect: Direct technology or Hypertext Transfer Protocol Service. SARS will validate each file and respond to inform the submitting entity of the outcome of the validated file.

Once the file has been successfully submitted, the user should be able to login on eFiling to view the pre-populated declaration. The entity will also use this channel to submit and authorise the declaration to SARS.

Notes:

- a) Submission via the Direct Data Flow requires enrolment and activation available on eFiling.

4. DATA VALIDATIONS TO BE PERFORMED

- a. When the proprietary system compiles the file a first level validation must be performed on all fields according to validation requirements set hereafter.
- b. The above validation is again performed when the data is received by SARS to ensure complete transmission.
- c. Before sending confirmation and acceptance of the submission SARS validates the submitted data against its systems. Submission will be rejected, accepted with warnings or partially uploaded if the data file fails this test.
- d. Data is checked against previous submissions to prevent “duplicate submissions” – which is the same data submitted multiple times.

5. GENERAL RULES FOR IMPORT FILE STRUCTURES

- a. All files submitted after the implementation date must be according to the new requirements regardless of the period.
- b. Each file submitted to SARS must only contain information for one submitting entity, one fund entity, one tax type (only Medical Scheme Contribution) and for one fiscal year.
- c. Each of the files are structured as follows:
 - Submission file header
 - Submitting entity data (fund administrator data)
 - Fund entity data (medical fund)
 - Principal member demographic data
 - Person paying account demographic data
 - Dependant demographic data
 - Principal member financial data
 - File trailer?
- d. Fields are indicated as mandatory, optional or conditional as specified in this document.
- e. Data fields must not start with a space.
- f. All accounts must be reported on.
- g. All files must conform to the LATIN-1 character encoding.
- h. A pipe delimited file format will be used, where the fields are separated by a pipe delimiter. For any field where no value is required or no value is available, the pipe delimiter must be followed by another pipe delimiter to indicate that the field is empty.
- i. Different types of validations as well as the sequence of validations to be performed on files submitted to SARS are as follows:
 - 1.SARS will reject an entire file under the following conditions:
 - File is corrupt, i.e. the file could not be read;
 - File fails structure validations, i.e. error(s) were found in the number of pipe separators in the submission file header, summary or line item level taxpayer data header, body or trailer, or specific field errors were found in the submission file header, summary or line item level taxpayer data header or trailer. Field validations on the file body are addressed in point 2 below.
 - 2.SARS will accept an entire file under the following conditions:
 - Zero fields were rejected;
 - One or more records were found to be duplicates.
 - 3.SARS will partially upload a file under the following conditions:
 - One or more record(s) were rejected, but not all records.

- j. The fields in the file body are each subjected to the following types of validations and in the sequence as described below:
1. Required: validates whether the field is required to be completed. Can be mandatory, conditional or optional. If the field is conditional, a condition rule is supplied;
 2. Data type: specifies the type for example, numeric or alpha numeric;
 3. Length type: indicates whether the length of the field can be variable or fixed;
 4. Length min: max specifies the minimum length and the maximum length a field can have. If the field has a fixed length type, the minimum and maximum lengths is the same. Based on the whether there is a condition rule is met, different minimum and maximum lengths are defined;
 5. Data validations: validates whether the field complies to format rules or belongs to a pre-defined set of values; and
 6. Logic validations: applies a logic validation on the value of the field.

Note: When records are being validated by SARS systems, the validations will be done in the sequence as described above. Once a field has failed any one of these validations no further validations will be done on that field. For example, if a field passes the required and data type validations (numbers 1 and 2 above) and then fails on length type (number 3), the length, data and logic validations will not be performed and the error on the length type will be recorded in the response file.

- k. File Structure Validations will be done in the sequence provided in the table below. If the file fails file structure validations (File Response Code = 005), then a File Response Reason will be provided in the response file header. In the instance where the file failed validations

No	Validation	File Response Reason
1	Does the file have a header, body and trailer identifier	Missing required section either header, body, or trailer
2	Does the generic header structure pass i.e. are there the correct amount of pipes	Generic header contains the incorrect number of fields
3	Does the trailer structure pass i.e. are the number of pipes correct	Trailer contains the incorrect number of fields
4	Does the submission file header structure pass i.e. are the number of pipes correct	Product header contains the incorrect number of fields
5	Does the body structure pass i.e. are the number of pipes correct and are the records submitted in the correct sequence	One or more body items contain the incorrect number of fields, or the records were submitted in the incorrect sequence
6	Validate the generic header data – actual content according to the spec	Invalid data in generic header
7	Validate the submission file header data – actual content according to the spec	Invalid data in submission file header

8	Validate the trailer: Is the correct data used in the correct fields – actual content according to spec	Invalid data in trailer
9	Validate the trailer: Do the calculated fields in the trailer add up	Trailer calculation failed

Note – if file did not pass validation numbers 1 to 6, then the acknowledgement of receipt cannot be issued and instead a rejection message will be sent.

- l. A pipe “|” character may not be used within any field value (e.g. as a special character). If it is, it will be regarded as the start of the next field.
- m. The sections submitted must be in the sequence as specified in the file. This implies the first record in the file will be the general header, the second record will be the submitting entity demographic record, third will be the fund entity data, then all the data pertaining to the principal member, and lastly the trailer record will follow.

6. FILE LAYOUTS

During the process of the submission of data to SARS a number of messages will be sent back and forth between the SARS systems, eFiling and the Direct Data Flow Channel depending on the data requested by SARS. The maximum number of messages is 3.

The table below indicates for each message, the file number and name to be used to convey that message. It also indicates the sender and recipient for each message. For each of the files, a detail file layout is provided in the sub paragraphs.

Message Number	Message Description	File Number	File Name	Sender	Recipient
1	Medical scheme contribution submission is required as determined by the Commissioner	1	Medical scheme contribution submission	3 rd Party application / eFiling	SARS systems
2	This response will be the acknowledgement of receiving data submission before any validations have been performed	2	Response	SARS systems	3 rd Party application
3	This response is the notification of whether the file was accepted, accepted with warnings, partially uploaded or rejected. If rejected the response includes a rejection reason	2	Response	SARS systems	3 rd Party application

File Name Structure Requirements

File Name	File Name Structure Requirements
Medical scheme contribution submission	Data Type Being Supplied (value of field 8)_ File Layout Version (value of field 4)_ Tax Reference Number (value of field 28)_ Unique File ID (value of field 5)_ Message Create Date (value of field 3)
Response	Data Type Being Supplied_ File Layout Version (value of field 4)_ Tax Reference Number_ Unique File ID_ Message Create Date_ "R"File Response Code

Notes:

- All the field values in the file name must be separated by a “_” and there must be no spaces between any characters.
- For the purpose of creating the file name the Message Create Date in the file name must be in the format CCYYMMDDThhmmss.
- The file name must be followed by a .psv or a .txt or a .zip extension

6.1 File Layout: 1. Medical Scheme Contributions Data Submission

This section lists all the fields that are required for the Medical Scheme Contributions file. The table specifies for each field, the required length, provides a description and also indicates the relevant validation rules.

Note 1: The number column is used to reference fields in the table for ease of use and does not indicate sequence in the file.

Note 2: The “Required”: “Type” field can have one of the following values:

- M = Mandatory: Implying the field must always be completed
- C = Conditional: Implying the field must always be completed under the defined conditions, else it can be left blank
- O = Optional: Implying the field can be completed if possible
- MW = Mandatory with warning: Implying from a SARS perspective this field is mandatory (as defined above), however due to constraints experienced by the submitting entities to provide the required data, the field can be left blank for a pre-defined time period and SARS will accept a record where such a mandatory field has not been completed. At the applicable time the field will revert to the intended Mandatory type and at such time SARS will reject the records if not completed.
- CW = Conditional with warning: Implying that from a SARS perspective, when the conditions are met, this field is mandatory, however due to constraints experienced by the submitting entities to provide the required data, the field can be left blank for a pre-defined time period and SARS will accept a record where such a field has not been completed under the specified conditions. At the applicable time the field will revert to the intended mandatory type when the conditions are met and at such time SARS will reject the records if not completed.

Note 3: The values for the “Length Type” column has been shortened to VAR (Variable) and FIX (Fixed) in order to save space.

Note 4: In order to enhance readability and understanding of some of the complex validation, the Field names used in the validations has been replaced with characters; e.g. Year of Assessment (Field 24) = X. Where this has been done, the list of field names replaced will appear at the start of the validation. The same character has not necessarily been used throughout for the same field name.

Note 5: File name definition – Refer to the file name structure table under Section 5.

Note 6: No negative values allowed – SARS will not permit negative values on the Member Financial Data. For instances where there are refunds, backdating, etc., the submitting entity must submit a correction for the applicable year of assessment.

No	Field Name	Description	Required		Data Type	Length Type	Length (Min:Max)	Data Validations	Logic Validations
			Type	Condition Rule					
SUBMISSION FILE HEADER									
1	Section Identifier	To identify the start of the section as well as identifying the type of section	M		A	FIX	1:1	a) Must = H, where H = Header	
2	Header Type	To indicate the type of header in order to differentiate between various types	M		A	VAR	1:3	a) Must = GH, where GH = General Header	
3	Message Create Date	Date and time that the message was created	M		FT	FIX	19:19	a) Format must be: CCYY-MM-DDTh:mm:ss b) 24h time format must be used	a) Must be less than or equal to today's date
4	File Layout Version	The version of the delimited file layout that is being submitted. Sequential number, which increments with one every time that the file layout version changes once files is being submitted to the production environment. This number is provided by SARS.	M		N	VAR	1:4	a) Must = 2 b) Value must not contain a decimal point Note – SARS will only support the version(s) specified above	a) Must be greater than or equal to 1 and less than or equal to 9999

No	Field Name	Description	Required		Data Type	Length Type	Length (Min:Max)	Data Validations	Logic Validations
			Type	Condition Rule					
5	Unique File ID	The submitting source must create this field when data is submitted to SARS. This field will uniquely identify this file when coupled with the source. This value must not be repeated by the submitting source (e.g. use the date time with some other unique number). This field will also be used to link the records to the original file. The field must be generated by the software from which the entity is submitting the data to SARS. When SARS sends the response file, the Unique File ID in the response file must be equal to the Unique File ID obtained from the file name of the submitted file	M		AN	VAR	1:64	<p>a) Value must not contain a decimal point</p> <p>b) Although this field is designed using the definition of AN (as specified in Section 1 of this document), SARS will also accept dashes "-" (this is to cater for entities that have chosen to make use of a GUID). Please note this is the only exception to the AN definition that will be permitted and only on this field.</p>	a) Must be unique per submission and across submissions per submitting entity
6	SARS Request Reference	In the scenario where SARS sends a request file to the entity requesting data, SARS provides this reference number to use in the file to be submitted to SARS. SARS also uses this reference number when responding to the taxpayer on files submitted to SARS	C	If Data Type Being Supplied = MED then this field must be left blank	AN	VAR	<p>a) 0:0– If this field is left blank</p> <p>b) 1:64– If this field is completed</p>		

No	Field Name	Description	Required		Data Type	Length Type	Length (Min:Max)	Data Validations	Logic Validations
			Type	Condition Rule					
7	Test Data Indicator	<p>This should be used to indicate if the data is for testing or is live data and should be processed. The purpose of the field is to avoid test data accidentally being processed in production and allow the source to test their submission without it being processed.</p> <p>Note – If SARS receives a value = T in the production environment or a value = L in the test environment, then the file will be validated, a response file will be returned, but the data will not be processed to the database.</p>	M		A	FIX	1:1	a) Must = T or L, where T = Test and L = Live	
8	Data Type Being Supplied	When data is submitted to SARS, this field indicates the type of data that can be found in the file, e.g. Dividends tax, VAT supporting data. When SARS sends a response on a file submitted, SARS indicates the data type on which the response is based.	M		AN	FIX	3:3	a) Must = MED, where MED = Medical scheme contributions extracts data	
9	Channel Identifier	Identifies the channel from which the file was submitted, e.g. Connect Direct The channel, from which the file was submitted to SARS, must generate this identifier.	M		AN	VAR	1:10	a) Must = CD or HTTPS, where CD = Connect Direct, HTTPS = Hypertext Transfer Protocol	

No	Field Name	Description	Required		Data Type	Length Type	Length (Min:Max)	Data Validations	Logic Validations
			Type	Condition Rule					
10	Source Identifier	<p>This identifies the file submitter and contains the security token. This value will be supplied by SARS via eFiling if the C: D or HTTPS channels are used.</p> <p>Note – For testing purposes please refer to the SARS website where a value will be supplied that can be used in the interim. This value will only be applicable for test purposes and will not be accepted in the production environment.</p>	M		FT	FIX	144:144		a) Validate that this value = the value supplied by SARS
11	Group ID	<p>If the amount of data requires that it be sent in multiple files, a unique Group ID must be created on the submitting entity's system to be able to link the multiple files to the one group</p>	M		AN	VAR	1:64	a) Although this field is designed using the definition of AN (as specified in Section 1 of this document), SARS will also accept dashes "-" (this is to cater for entities that have chosen to make use of a GUID). Please note this is the only exception to the AN definition that will be permitted and only on this field	a) Must not be equal to a Group ID used in a previously successfully submitted group file submission per submitting entity

No	Field Name	Description	Required		Data Type	Length Type	Length (Min:Max)	Data Validations	Logic Validations
			Type	Condition Rule					
12	Group Total	<p>Number of files that make up a group, e.g. if the amount of data requires three files to be submitted, then the Group Total must be 3.</p> <p>For example, where it is required for data to be submitted in one file and the file is too large to accommodate the submission in a single file, the file can be split into smaller more manageable files and this field must then indicate the total number of files that make up the submission.</p> <p>Note: If a group of files is submitted, the files will be kept until all the files as indicated by the Group Total have been received before the files are processed. If all the files have not been received within 5 working days, the files will be rejected as an incomplete group"</p>	M		N	VAR	1:4	a) Value must not contain a decimal point	a) Must be greater than or equal to 1 and less than or equal to 9999

No	Field Name	Description	Required		Data Type	Length Type	Length (Min:Max)	Data Validations	Logic Validations
			Type	Condition Rule					
13	Unique Group Item ID	The number of this file in the group. This number must be an incrementing number beginning at one for each group submission, and incrementing by 1 for each file in the group. E.g. if this is the second file of the group this field must be 2.	M		N	VAR	1:4	a) Value must not contain a decimal point	a) Must be equal to or greater than 1 b) Must be less than or equal to the Group Total c) Must be submitted in sequence
14	Source System	The name of the system from where the data was generated, e.g. Pastel or SAP	M		FT	VAR	1:30		
15	Source System Version	The version number system, e.g. 1.1.7.	M		FT	VAR	1:10		
16	Contact Person Name	The full names of the person to be contacted with technical queries related to this file	M		FT	VAR	1:90		
17	Contact Person Surname	The surname of the person to be contacted with technical queries related to this file	M		FT	VAR	1:53		
18	Business Telephone Number 1	The primary contact telephone number for contact person	C	a) At least one of Business Telephone Number 1 or the Cell Phone Number field must be completed	AN	VAR	a) 0:0 - No condition met b) 9:15 - Condition met	a) Only numeric values are allowed b) No spaces are allowed c) + is not allowed d) Value must not contain a decimal point	

No	Field Name	Description	Required		Data Type	Length Type	Length (Min:Max)	Data Validations	Logic Validations
			Type	Condition Rule					
19	Business Telephone Number 2	A secondary contact telephone number for contact person	O		AN	VAR	a) 0:0 – if this field is blank b) 9:15 – if this field is completed	a) Only numeric values are allowed b) No spaces are allowed c) + is not allowed d) Value must not contain a decimal point	
20	Cell Phone Number	The cell phone number of the contact person	C	a) At least one of Business Telephone Number 1 or the Cell Phone Number field must be completed	AN	VAR	a) 0:0 - No condition met b) 9:15 – Condition met	a) Only numeric values are allowed b) No spaces are allowed c) + is not allowed d) Value must not contain a decimal point e) No spaces are allowed	
21	Contact Email	The email address for the contact person	M		FT	VAR	5:80	a) Must contain one @ sign b) Must contain a domain which must be indicated with a dot (.)	
SUBMITTING ENTITY DATA (FUND ADMINISTRATOR)									
22	Section Identifier	To identify the start of the section as well as identifying the type of section	M		A	FIX	1:1	a) Must = H , where H = Header	
23	Header Type	To indicate the type of header in order to differentiate between various types	M		A	VAR	1:3	a) Must = SE, where SE = Submitting Entity	

No	Field Name	Description	Required		Data Type	Length Type	Length (Min:Max)	Data Validations	Logic Validations
			Type	Condition Rule					
24	Year of Assessment	Tax year to which the certificate applies	M		N	FIX	4:4	a) Format CCYY	a) Must be greater than or equal to 2013
25	Period Start Date	The starting date for the period that is reported by this medical scheme contribution extract	M		N-FT	FIX	10:10	a) Format CCYY-MM-DD	a) Date must be greater than or equal to 1 March of the Submission Tax year
26	Period End Date	The ending date for the period that is reported by this medical scheme contribution extract	M		N-FT	FIX	10:10	a) Format CCYY-MM-DD	a) Date can only be less than or equal to 28/29 February of the Submission Tax year
167	Submission Period Indicator	Refers to whether submission is bi-annual or year-end. E.g. CCYY-08 for bi-annual or CCYY-02 for year-end	M		FT	FIX	7:7	a) CCYY-MM	a) Can be CCYY-08 or CCYY-02
168	Nature of Person	The type/ category of the submitting entity.	M		FT	VAR	9:33	a) Refer to Appendix F: Nature of Person Table	a) Value must not = INDIVIDUAL or FOREIGN_INDIVIDUAL or INDIVIDUAL_EST ATE
27	Information supplied by- Name of submitting entity Registered Name	Referring to the fund submitting entity /administrator name Registered name of the submitting entity	M		FT	VAR	1:60120		
169	Trading name	The name the submitting entity is trading under.	M		FT	VAR	1:120		

No	Field Name	Description	Required		Data Type	Length Type	Length (Min:Max)	Data Validations	Logic Validations
			Type	Condition Rule					
170	Registration number	The registration number of the submitting entity	C	<p>If the value of Nature of person (Field 168) = PUBLIC_CO or PRIVATE_CO or INTERVIVOS_TRUST or RETIREMENT_FUND or CLOSE_CORPORATION or FOREIGN COMPANY, then Registration number (Field 170) is mandatory.</p> <p>For any other Nature of person (Field 168), this field can be left blank.</p>	FT	VAR	<ul style="list-style-type: none"> 0:0 – No condition met 1:15 – Condition met 	a) If the value of Nature of person (Field 168) = PUBLIC_CO or PRIVATE_CO, then refer to Appendix G for the applicable validation that must be applied.	
28	Submitting Entity Income Tax Reference Number	Referring to submitting entity/fund administrator Income Tax Reference Number as registered at SARS	M		N	FIX	10:10	a) Refer to Appendix H	<p>a) Modulus 10 check for IT reference number. Refer to section 7.1 for the applicable modulus check</p> <p>a) The first character can only be 0, 1, 2, 3, 7, or 9</p> <p>b) Verify if this value exists on SARS system – if not then reject the entire file</p>

No	Field Name	Description	Required		Data Type	Length Type	Length (Min:Max)	Data Validations	Logic Validations
			Type	Condition Rule					
171	Postal address line 1	The first line of the submitting entity's postal address.	M		FT	VAR	1:100		
172	Postal address line 2	The second line of the submitting entity's postal address.	O		FT	VAR	a) 0:0 – Not completed b) 1:100 – Completed		
173	Postal address line 3	The third line of the submitting entity's postal address.	O		FT	VAR	a) 0:0 – Not completed b) 1:100 – Completed		
174	Postal address line 4	The fourth line of the submitting entity's postal address.	O		FT	VAR	a) 0:0 – Not completed b) 1:100 – Completed		
175	Postal code	The postal code of the submitting entity's postal address.	M		AN	VAR	1:10	a) Although this field is designed using the definition of AN (as specified in section 1.2.2 of this document), SARS will also accept spaces " " (this is to cater for foreign postal codes). Please note this is the only exception to the AN definition that will be permitted and only on this field	

No	Field Name	Description	Required		Data Type	Length Type	Length (Min:Max)	Data Validations	Logic Validations
			Type	Condition Rule					
FUND ENTITY DATA									
29	Section Identifier	To identify the start of the section as well as identifying the type of section	M		A	FIX	1:1	a) Must = B , where B = Body	
30	Record Type	Type of transaction	M		AN	VAR	1:6	a) Must = FE, where FE = Fund Entity	
161	Row Number	Number of the row in the file, sequential number starting at 1 for every file submitted to SARS. In the response file, this must be the rejected row(s) from the incoming file. The row number field must start at 1 for every new file and must increment by 1 for every new row added that is classed as a body record in the file. The last body record row number in the file must be equal to the total records supplied in the trailer. This would imply that for every file the body records start at 1 and increment by 1 for each record regardless of how many different sections there might be in the body, for files where there are multiple sections in the body	M		N	VAR	1:10	a) An incrementing number per record beginning at 1 for each file b) Value must not contain a decimal point	a) Must be greater than or equal to 1 and smaller than or equal to the total number of rows in the file with Section Identifier = B

No	Field Name	Description	Required		Data Type	Length Type	Length (Min:Max)	Data Validations	Logic Validations
			Type	Condition Rule					
31	Year of Assessment	Tax year to which the certificate applies	M		N	FIX	4:4	a) Format CCYY	a) Must be greater than or equal to 2013 b) Must equal to submitting entity year of assessment (field 24)
32	Period Start Date	The starting date for the period that is reported by this medical scheme contributions extract	M		NFT	FIX	10:10	a) Format CCYY-MM-DD	a) Date must be greater than or equal to 1 March of the Submission Tax year
33	Period End Date	The ending date for the period that is reported by this medical scheme contributions extract	M		NFT	FIX	10:10	a) Format CCYY-MM-DD	a) Date can only be less than or equal to 28/29 February of the Submission Tax year
176	Nature of Person	The type/ category of the submitting entity.	M		FT	VAR	9:33	a) Refer to Appendix F: Nature of Person Table	a) Value must not = INDIVIDUAL or FOREIGN_INDIVIDUAL or INDIVIDUAL_ESTATE
34	Name of Fund Entity Registered Name	Referring to the organisation for whom the file is being submitted, in this case, the fund entity Registered name of the fund entity	M		FT	VAR	1_60120		

No	Field Name	Description	Required		Data Type	Length Type	Length (Min:Max)	Data Validations	Logic Validations
			Type	Condition Rule					
35	Fund Entity Income Tax Reference Number	Referring to fund entity's Income Tax Reference Number	O		N	FIX	10:10	a) Refer to Appendix H	a) Modulus 10 check for IT reference number. Refer to section 7.1 for the applicable modulus check b)a) The first character can only be 0, 1, 2, 3 or 9 e)b) Verify if this value exists on SARS system – if not then reject the entire file
36	Registered Medical Scheme Number	Fund entity's registered medical scheme number	M		AN	VAR	1:20		
37	Total number of principal members at start of financial year	Indicates total number of principal members for the fund at start of financial year (excluding dependents)	M		N	VAR	1:15	a) Value must not contain a decimal	
38	Total number of principal members that joined during financial year	Indicates total number of principal members that joined the fund during financial year (excluding dependents)	M		N	VAR	1:15	a) Value must not contain a decimal	
39	Total number of principal members that resigned during financial year	Indicates total number of principal members that resigned from fund membership during financial year	M		N	VAR	1:15	a) Value must not contain a decimal	

No	Field Name	Description	Required		Data Type	Length Type	Length (Min:Max)	Data Validations	Logic Validations
			Type	Condition Rule					
40	Total number of principal members at end of financial year	Indicates total number of principal members for the fund at the end of financial year (excluding dependents)	M		N	VAR	1:15	a) Value must not contain a decimal	a) Must equal to total number of principal members at start of financial year plus total number of principal members that joined during financial year minus total number of principal members that resigned during financial year (=field 37 + field 38 – field 39)
41	Total fund contributions made by employer for the financial year	Sum of total fund contributions made for the financial year by employer	M		N	VAR	4:18	a) If 1.00 or greater, no leading zeros allowed. If <1.00, there must be 1 zero before the decimal b) Must be greater than or equal to 0.00 and smaller than or equal to 99999999999999.99 c) Must always have 2 values after the decimal point to denote cent	

No	Field Name	Description	Required		Data Type	Length Type	Length (Min:Max)	Data Validations	Logic Validations
			Type	Condition Rule					
42	Total contributions made by principal members for the financial year	Sum of total contributions made for the financial year by all the principal members	M		N	VAR	4:18	<p>a) If 1.00 or greater, no leading zeros allowed. If <1.00, there must be 1 zero before the decimal</p> <p>b) Must be greater than or equal to 0.00 and smaller than or equal to 999999999999.99</p> <p>c) Must always have 2 values after the decimal point to denote cent</p>	

No	Field Name	Description	Required		Data Type	Length Type	Length (Min:Max)	Data Validations	Logic Validations
			Type	Condition Rule					
43	Total contributions for the financial year	Sum of total fund contributions made for the financial year by both the employer and principal members	M		N	VAR	4:18	a) If 1.00 or greater, no leading zeros allowed. If <1.00, there must be 1 zero before the decimal b) Must be greater than or equal to 0.00 and smaller than or equal to 999999999999.99 c) Must always have 2 values after the decimal point to denote cent	a) Must equal to sum of total fund contributions made by employer for financial year plus total contributions made by principal members for the financial (= field 41 + field 42)
PRINCIPAL MEMBER DEMOGRAPHIC DATA									
44	Section Identifier	To identify the start of the section as well as identifying the type of section	M		A	FIX	1:1	a) Must = B, where B = Body	
45	Record Type	Type of transaction	M		AN	VAR	1:6	a) Must = PMDD, where PMDD= Principal Member Demographic Data	

No	Field Name	Description	Required		Data Type	Length Type	Length (Min:Max)	Data Validations	Logic Validations
			Type	Condition Rule					
46	Record Status	<p>The taxpayer's system must indicate whether a record is active, i.e. valid for the submission or must be cancelled from the submission</p> <p>Note: Record statuses that are deemed active are new, additions and corrections. Record statuses that are deemed cancelled are deletions.</p> <p>Indicates the status of the record, whether it is a new record, an adjusted record or a record that must be deleted</p>	M		A	FIX	1:1	<p>a) Must = A or C, where A = Active and C = Cancelled</p> <p>b) Record status can only be one of:</p> <ul style="list-style-type: none"> N = New Record; C = Correction D = Delete record <p>Note: The statuses must be used as follows:</p> <ul style="list-style-type: none"> N – Indicate a new record that has not been submitted before; C – Indicate that a previously submitted record is amended; D – Indicate that a previously submitted record must be deleted. 	

No	Field Name	Description	Required		Data Type	Length Type	Length (Min:Max)	Data Validations	Logic Validations
			Type	Condition Rule					
47	Unique Number	The taxpayer's system must generate a unique number for each record. In the response file, the unique number would be the number specified in the file submitted to SARS to enable the submitting entity's source system to identify the line that is being responded on by SARS.	M		FT	VAR	1:100		a) If the record status (field 46) = C or D, then this number must contain the number that was originally submitted b) Must be unique within the section across all files
48	Row Number	Number of the row in the file, sequential number starting at 1 for every file submitted to SARS. In the response file, this must be the rejected row(s) from the incoming file. The row number field must start at 1 for every new file and must increment by 1 for every new row added that is classed as a body record in the file. The last body record row number in the file must be equal to the total records supplied in the trailer. This would imply that for every file the body records start at 1 and increment by 1 for each record regardless of how many different sections there might be in the body, for files where there are multiple sections in the body	M		N	VAR	1:10	a) An incrementing number per record beginning at 1 for each file b) Value must not contain a decimal point	a) Must be greater than or equal to 1 and smaller than or equal to the total number of rows in the file with Section Identifier = B

No	Field Name	Description	Required		Data Type	Length Type	Length (Min:Max)	Data Validations	Logic Validations
			Type	Condition Rule					
5049	Unique Membership Number	Principal member's unique membership number	M		AN	VAR	1:36		a) Must equal to a MED Unique Number where Record Type = PMDD
5450	MED Unique Number	Number is unique only to principal member (to be created and used IF membership number is not unique)	C	Mandatory if membership number is not unique	AN	VAR	1:36		a) Must equal to a MED Unique Number where Record Type = PMDD
51	Principal Member Nature of Person Code	Nature of person code	M		N-FT	Fixed VAR	2:2 9:33	The valid tax category code table is provided below: 01-Individual a) Refer to Appendix F: Nature of Person Table	a) Must = 01 where 01 is individual or foreign individual as medical scheme can only be offered to an individual NoP, i.e. cannot be offered to a Company or a Trust.
52	Membership Commencement Date	Date on which principal member joined the fund	M		FT	FIX	10:10	a) Format CCYY-MM-DD	a) Must be smaller than today's date OR equal to today's date
53	Principal Member Surname	Personal particulars – Surname of the individual	M		FT	VAR	1:120		
54	Principal Member Initials	Personal particulars – Initials applicable only to individuals	MW	Mandatory for Individuals	FT	VAR	a) 0:0 - No condition met b) 1:30 – Condition met		
55	Principal Member Names	Personal particulars – The first two name applicable only to individuals	M	Mandatory for Individuals	FT	VAR	a) 0:0 - No condition met b) 1:90 – Condition met	a) Names must be separated by a single space	

No	Field Name	Description	Required		Data Type	Length Type	Length (Min:Max)	Data Validations	Logic Validations
			Type	Condition Rule					
56	Principal Member Identity Number	Personal particulars – South African identify number of the individual taxpayer	C	At least one of the Principal Member Identity number, Principal Member Passport Number or Principal Member Date of Birth fields must be completed for Individuals Mandatory if Individual Nature of Person was selected (i.e. Principal Member is South African)	N	FIX	a) 0:0 - No condition met b) 13:13 – Condition met	a) Identification number should not contain any special characters b) If Nature of Person (field 51) = Individual, then refer to Appendix I: for the ID validation that must be applied	a) Modulus test for identity number. Refer to section 7.2 Identification Number for the applicable modulus check
57	Principal Member Passport Number	Passport number or other number (non-bar-coded RSA ID numbers) of the principal member.	C	At least one of the Principal Member Identity number, Principal Member Passport Number or Principal Member Date of Birth fields must be completed for Individuals Mandatory if Foreign Individual Nature of Person was selected (i.e. Principal Member is not a South African, field 51)	AN	VAR	a) 0:0 – no condition met b) 6:20 – condition met	a) Minimum of 6 characters b) No spaces are allowed	

No	Field Name	Description	Required		Data Type	Length Type	Length (Min:Max)	Data Validations	Logic Validations
			Type	Condition Rule					
58	Principal Member Passport Country of Issue	Indicates the country that issued the passport	C	Mandatory if Passport Number has been completed	AN	FIX	a) 0:0 – no condition met a) 3:3 2:2 – condition met	a) Refer to Appendix B for passport country of issue codes b) If this value = ZAF then Principal Member Identity number must be completed	
59	Principal Member Income Tax Reference Number	SARS assigned Income tax reference number - Personal particulars	MW		N	FIX	a) 0:0 – if this field is blank b) 10:10 – if this field is completed	a) Refer to Appendix H	a) Modulus 10 check for IT reference number. Refer to section 7.1 Tax Reference Number for the applicable modulus check The first character can only be 0, 1, 2, 3, or 9

No	Field Name	Description	Required		Data Type	Length Type	Length (Min:Max)	Data Validations	Logic Validations
			Type	Condition Rule					
60	Principal Member Date of Birth	Principal Member date of birth	CM	At least one Principal Member Identity number, Principal Member Passport Number or Principal Member Date of Birth field must be completed for Individuals Mandatory for Individuals if nature of person is individual or foreign individual or individual estates (Field 51)	NFT	FIX	a) 0:0 – no condition met b) 10:10 – condition met	a) Format CCYY-MM-DD b) Date must not be greater than the current date	
61	Principal Member Address Details - Physical: Unit number	Indicates unit number of the Principal Member Physical address.	O		AN	VAR	0:5		
62	Principal Member Address Details - Physical: Complex	Indicates the complex name of the Principal Member Physical address.	O		FT	VAR	0:25		
63	Principal Member Address Details - Physical: Street Number	Indicates the street number of the Principal Member Physical address.	O		AN	VAR	0:5		

No	Field Name	Description	Required		Data Type	Length Type	Length (Min:Max)	Data Validations	Logic Validations
			Type	Condition Rule					
64	Principal Member Address Details - Physical: Street/Name of Farm	Indicates the street / name of farm of the Principal Member Physical address.	CW	a) At least one, Physical address or Postal address must be completed b) If Principal Member Postal Address Line 1 is not completed this field is mandatory	FT	VAR	a) 0:0 – no condition met b) 1:25 – condition met		
65	Principal Member Address Details - Physical: Suburb/District	Indicates the suburb / district of Principal Member Physical address	CW	a) If Principal Member Address Details - Physical: Street/Name of Farm is completed this field is conditional – at least one the Suburb/District field or the City/Town fields must be completed	FT	VAR	a) 0:0 – no condition met b) 1:34 – condition met		

No	Field Name	Description	Required		Data Type	Length Type	Length (Min:Max)	Data Validations	Logic Validations
			Type	Condition Rule					
66	Principal Member Address Details - Physical: City/Town	Indicates the city / town of Principal Member Physical address	CW	a) If Principal Member Address Details - Physical: Street/Name of Farm is completed this field is conditional – at least one the Suburb/District field or the City/Town fields must be completed	FT	VAR	a) 0:0 – no condition met b) 1:23 – condition met		
67	Principal Member Address Details - Physical: Postal Code	Indicates the postal code of the Principal Member Physical address	CW	a) If Principal Member Address Details - Physical: Street/Name of Farm is completed, this field is mandatory	AN	VAR	a) 0:0 – no condition met b) 1:10 – condition met		a) In case there is no postal code for the residential address, use the nearest postal code
68	Postal Address same as Physical Address indicator	Indicates if the Principal Member Postal Address is the same as the physical address	O-M		A	FIX	1:1	Must = "Y" or "N", where Y = Yes and N = No	

No	Field Name	Description	Required		Data Type	Length Type	Length (Min:Max)	Data Validations	Logic Validations
			Type	Condition Rule					
69	Principal Member Postal Address Line 1	Line 1 of the Postal address of Principal Member	CW	a) At least one Physical address or Postal address field must be completed b) If Principal Member Address Details - Physical: Street/Name of Farm is not completed this field is mandatory	FT	VAR	a) 0:0 – condition met no b) 1:35 – condition met		
70	Principal Member Postal Address Line 2	Line 2 of the Postal address of Principal Member	O		FT	VAR	0:35		
71	Principal Member Postal Address Line 3	Line 3 of the Postal address of Principal Member	O		FT	VAR	0:35		
72	Principal Member Postal Address Line 4	Line 4 of the Postal address of Principal Member	O		FT	VAR	0:35		
73	Principal Member Postal Code	Postal code of the Principal Member	CW	If Principal Member Postal Address Line 1 is completed this field is mandatory	AN	VAR	a) 0:0 – no condition met b) 1:10 – condition met		

No	Field Name	Description	Required		Data Type	Length Type	Length (Min:Max)	Data Validations	Logic Validations
			Type	Condition Rule					
74	Total Number of Dependants Indicator	Indicates the total number of dependents on the principal member's medical scheme (excluding the principal member)	M		N	VAR	1:2	Value must not contain a decimal	a) If average of Fields 75 to 86 = 1 then Field 74 has to contain a value = 0 OR b) If average of Fields 75 to 86 > 1 then Field 74 has to contain a value > 0
75	Total Number of Members in March	Indicates principal member plus the total number of dependents	M		N	VAR	1:2	a) Value must not contain a decimal	a) This field has to contain a value > 0
76	Total Number of Members in April	Indicates principal member plus the total number of dependents	M		N	VAR	1:2	a) Value must not contain a decimal	a) This field has to contain a value > 0
77	Total Number of Members in May	Indicates principal member plus the total number of dependents	M		N	VAR	1:2	a) Value must not contain a decimal	a) This field has to contain a value > 0
78	Total Number of Members in June	Indicates principal member plus the total number of dependents	M		N	VAR	1:2	a) Value must not contain a decimal	a) This field has to contain a value > 0
79	Total Number of Members in July	Indicates principal member plus the total number of dependents	M		N	VAR	1:2	a) Value must not contain a decimal	a) This field has to contain a value > 0
80	Total Number of Members in August	Indicates principal member plus the total number of dependents	M		N	VAR	1:2	a) Value must not contain a decimal	a) This field has to contain a value > 0
81	Total Number of Members in September	Indicates principal member plus the total number of dependents	M		N	VAR	1:2	a) Value must not contain a decimal	a) This field has to contain a value > 0

No	Field Name	Description	Required		Data Type	Length Type	Length (Min:Max)	Data Validations	Logic Validations
			Type	Condition Rule					
82	Total Number of Members in October	Indicates principal member plus the total number of dependents	M		N	VAR	1:2	a) Value must not contain a decimal	a) This field has to contain a value > 0
83	Total Number of Members in November	Indicates principal member plus the total number of dependents	M		N	VAR	1:2	a) Value must not contain a decimal	a) This field has to contain a value > 0
84	Total Number of Members in December	Indicates principal member plus the total number of dependents	M		N	VAR	1:2	a) Value must not contain a decimal	a) This field has to contain a value > 0
85	Total Number of Members in January	Indicates principal member plus the total number of dependents	M		N	VAR	1:2	a) Value must not contain a decimal	a) This field has to contain a value > 0
86	Total Number of Members in February	Indicates principal member plus the total number of dependents	M		N	VAR	1:2	a) Value must not contain a decimal	a) This field has to contain a value > 0
177	Member Cell Phone Number	The cell phone number of the Member	O		AN	VAR	a) 0:0 - No condition met b) 9:15 - Condition met	a) Only numeric values are allowed b) No spaces are allowed c) + is not allowed d) Value must not contain a decimal point e) No spaces are allowed	
178	Member Contact Email	The email address for the Member	O		FT	VAR	5:80	a) Must contain one @ sign b) Must contain a domain which must be indicated with a dot (.)	

No	Field Name	Description	Required		Data Type	Length Type	Length (Min:Max)	Data Validations	Logic Validations
			Type	Condition Rule					
87	Person Paying Account indicator	This refers to the person who pays the account, which can in some instances be different to the Principal Member. If this is the case, the demographic details of the individual paying the account are required.	M		A	FIX	1:1	a) Must = "Y" or "N", where "Y" if Principal Member is responsible for paying the account and "N" if Principal Members is not responsible for paying the account	
PERSON PAYING ACCOUNT DEMOGRAPHIC DATA (If Person Paying Account Indicator = "N", then this record is mandatory)									
88	Section Identifier	To identify the start of the section as well as identifying the type of section	M		A	FIX	1:1	a) Must = B, where B = Body	
89	Record Type	Type of transaction	M		AN	VAR	1:6	a) Must = PPADD, where PPADD= Person Paying Account Demographic Data	

No	Field Name	Description	Required		Data Type	Length Type	Length (Min:Max)	Data Validations	Logic Validations
			Type	Condition Rule					
90	Record Status	<p>The taxpayer's system must indicate whether a record is active, i.e. valid for the submission or must be cancelled from the submission</p> <p>Note: Record statuses that are deemed active are new, additions and corrections. Record statuses that are deemed cancelled are deletions.</p> <p>Indicates the status of the record, whether it is a new record, an adjusted record or a record that must be deleted</p>	M		A	FIX	1:1	<p>a) Must = A or C, where A = Active and C = Cancelled</p> <p>b)a) Record status can only be one of: N = New Record; C = Correction D= Delete record</p> <p>Note: The statuses must be used as follows:</p> <ul style="list-style-type: none"> • N – Indicate a new record that has not been submitted before; • C – Indicate that a previously submitted record is amended; • D – Indicate that a previously submitted record must be deleted. 	

No	Field Name	Description	Required		Data Type	Length Type	Length (Min:Max)	Data Validations	Logic Validations
			Type	Condition Rule					
91	Unique Number	The taxpayer's system must generate a unique number for each record. In the response file, the unique number would be the number specified in the file submitted to SARS to enable the submitting entity's source system to identify the line that is being responded on by SARS.	M		FT	VAR	1:100		Must be unique within the section across all files
92	Row Number	Number of the row in the file, sequential number starting at 1 for every file submitted to SARS. In the response file, this must be the rejected row(s) from the incoming file. The row number field must start at 1 for every new file and must increment by 1 for every new row added that is classed as a body record in the file. The last body record row number in the file must be equal to the total records supplied in the trailer. This would imply that for every file the body records start at 1 and increment by 1 for each record regardless of how many different sections there might be in the body, for files where there are multiple sections in the body.	M		N	VAR	1:10	<ul style="list-style-type: none"> a) An incrementing number per record beginning at 1 for each file b) Value must not contain a decimal point 	<ul style="list-style-type: none"> a) Must be greater than or equal to 1 and smaller than or equal to the total number of rows in the file with Section Identifier = B

No	Field Name	Description	Required		Data Type	Length Type	Length (Min:Max)	Data Validations	Logic Validations
			Type	Condition Rule					
93	Unique Membership Number	Principal Member's unique membership number	M		AN	VAR	1:36		a) Must equal to a MED Unique Membership Number where Record Type = PMDD
94	MED Unique Number	Number is unique only to Principal Member (to be created and used IF membership number is not unique)	C	Mandatory if membership number is not unique	AN	VAR	1:36		a) Must equal to a MED Unique Number where Record Type = PMDD
95	Person Paying Account Nature of Person Code	NATURE OF PERSON CODE	M		FT	VAR	9:33	a) Refer to Appendix F: Nature of Person Table The valid tax category code table is provided below. 01 Individual 02 Company/CC 03 Trust 04 Public/Local authority & Municipality 06 Partnership 13 Foreign Individual 14 Foreign Company 15 Other	
96	Person Paying Account Surname/ Registered Name	Personal particulars – Surname of the individual or REGISTERED NAME OF THE ORGANISATION	M		FT	VAR	1:120		

No	Field Name	Description	Required		Data Type	Length Type	Length (Min:Max)	Data Validations	Logic Validations
			Type	Condition Rule					
97	Person Paying Account Initials	Personal particulars – Initials applicable only to individuals	MW	Mandatory for Individuals if nature of person is individual or foreign individual or individual_estates (Field 95)	FT	VAR	a) 0:0 - No condition met b) 1:30 – Condition met		
98	Person Paying Account Names	Personal particulars – The first two names applicable only to individuals	M	Mandatory for Individuals. if nature of person is individual or foreign individual or individual_estates (Field 95)	FT	VAR	a) 0:0 - No condition met b) 1:90 – Condition met	Names must be separated by a single space	

No	Field Name	Description	Required		Data Type	Length Type	Length (Min:Max)	Data Validations	Logic Validations
			Type	Condition Rule					
99	Person Paying Account Identity Number	Personal particulars – South African identify number of the individual taxpayer	C	At least one of the Person Paying Account Identity number, Person Paying Account Passport Number or Person Paying Account Date of Birth fields must be completed for Individuals Mandatory if Individual Nature of Person was selected (i.e. Principal Member is South African)	N	FIX	a) 0:0 - No condition met b) 13:13 – Condition met	a) Identification number should not contain any special characters b) If Nature of Person (field 95) = Individual, then refer to Appendix I for the ID validation that must be applied	Modulus test for identity number. Refer to section 7.2 Identification Number for the applicable modulus check

No	Field Name	Description	Required		Data Type	Length Type	Length (Min:Max)	Data Validations	Logic Validations
			Type	Condition Rule					
100	Person Paying Account Passport Number	Passport number or other number (non-bar-coded RSA ID numbers) of the Person Paying Account	C	At least one of the Person Paying Account Identity number, Person Paying Account Passport Number or Person Paying Account Date of Birth fields must be completed for Individuals Mandatory if Foreign Individual Nature of Person was selected (i.e. Principal Member is not a South African, field 95)	AN	VAR	a) 0:0 – no condition met b) 6:20 – condition met	a) No spaces are allowed	
101	Person Paying Account Passport Country of Issue	Indicates the country that issued the passport	C	Mandatory if Passport Number has been completed	AN	FIX	a) 0:0 – no condition met b) 2:2 – condition met	a) Refer to Appendix B: Codes for the country that issued passport b) If this value = ZAF then Person Paying Account Identity number must be completed	
102	Person Paying Account Income Tax Reference Number	SARS assigned income tax reference number - Personal particulars	O		N	FIX	a) 0:0 – if this field is blank b) 10:10 – if this field is completed	a) Refer to Appendix H	a) Modulus 10 check for IT reference number. Refer to section 7.1 Tax Reference Number for the applicable modulus check The first character can only be 0, 1, 2, 3, or 9

No	Field Name	Description	Required		Data Type	Length Type	Length (Min:Max)	Data Validations	Logic Validations
			Type	Condition Rule					
103	Person Paying Account Other Registration Number	Entity registration number with a recognised institution or body in SA e.g. CC number	O	<p>a) If Person Paying Account Nature of person = 4 (individual) this field must be blank</p> <p>b) If Person Paying Account Nature of person = (2 or 3), public co, private co, close corporation, intervivos trust, this field must be populated</p> <p>If Person Paying Account Nature of person = (4-15), For all other Nature of Persons, this field must be blank</p>	AN	VAR	a) 0:30	<p>a) Invalid if it consist of alpha only or special characters only</p> <p>b) If Person Paying Account Nature of person = 2, public co, private co, close corporation, this field must have the following format CCYY/NNNNN N/NN</p>	<p>a) If Person Paying Account Nature of person = 2, public co, private co, close corporation, the CCYY must be validated to be from 1800 and up but smaller than current calendar year. The last two digits of this number must be validated to be either of the following: 06, 07, 08, 09, 10, 11, 20, 21, 22, 23, 24, 25, 26.</p>

No	Field Name	Description	Required		Data Type	Length Type	Length (Min:Max)	Data Validations	Logic Validations
			Type	Condition Rule					
104	Person Paying Account Date of Birth	Person paying account date of birth	C	<p>c) At least one Person Paying Account Identity number, Person Paying Account Passport Number or Person Paying Account Date of Birth field must be completed for Individuals</p> <p>a) Mandatory for Individuals if nature of person is individual or foreign individual or individual estates (Field 95)</p>	NFT	FIX	<p>a) 0:0 – no condition met</p> <p>b) 10:10 – condition met</p>	<p>a) Format CCYY-MM-DD</p> <p>b) Date must not be greater than the current date</p>	
105	Person Paying Account Address Details - Physical: Unit number	Indicates unit number of the Person Paying Account Physical address.	O		AN	VAR	0:5		

No	Field Name	Description	Required		Data Type	Length Type	Length (Min:Max)	Data Validations	Logic Validations
			Type	Condition Rule					
106	Person Paying Account Address Details - Physical: Complex	Indicates the complex name of the Person Paying Account Physical address.	O		FT	VAR	0:25		
107	Person Paying Account Address Details - Physical: Street Number	Indicates the street number of the Person Paying Account Physical address.	O		AN	VAR	0:5		
108	Person Paying Account Address Details - Physical: Street/Name of Farm	Indicates the street / name of farm of the Person Paying Account Physical address.	CW	a) At least one, Physical address or Postal address must be completed If Person Paying Account Postal Address Line 1 is not completed this field is mandatory	FT	VAR	a) 0:0 – no condition met b) 1:25 – condition met		

No	Field Name	Description	Required		Data Type	Length Type	Length (Min:Max)	Data Validations	Logic Validations
			Type	Condition Rule					
109	Person Paying Account Address Details - Physical: Suburb/District	Indicates the suburb / district of Person Paying Account Physical address	CW	a) If Person Paying Account Address Details - Physical: Street/Name of Farm is completed this field is conditional – at least one the Suburb/District field or the City/Town fields must be completed	FT	VAR	a) 0:0 – no condition met b) 1:34 – condition met		
110	Person Paying Account Address Details - Physical: City/Town	Indicates the city / town of Person Paying Account Physical address	CW	a) If Person Paying Account Address Details - Physical: Street/Name of Farm is completed this field is conditional – at least one the Suburb/District field or the City/Town fields must be completed	FT	VAR	a) 0:0 – no condition met b) 1:23 – condition met		

No	Field Name	Description	Required		Data Type	Length Type	Length (Min:Max)	Data Validations	Logic Validations
			Type	Condition Rule					
111	Person Paying Account Address Details - Physical: Postal Code	Indicates the postal code of the Person Paying Account Physical address	CW	a) If Person Paying Account Address Details - Physical: Street/Name of Farm is completed, this field is mandatory	AN	VAR	a) 0:0 – no condition met b) 1:10– condition met		a) In case there is no postal code for the residential address, use the nearest postal code
112	Postal Address same as Physical Address indicator	Indicates if the Person Paying Account Postal Address is the same as the physical address	O		A	FIX	a) 1:1	a) Must = "Y" or "N", where Y = Yes and N = No	
113	Person Paying Account Postal Address Line 1	Line 1 of the Postal address of Person Paying Account	CW	a) At least one Physical address or Postal address field must be completed b) If Person Paying Account Address Details - Physical: Street/Name of Farm is not completed this field is mandatory	FT	VAR	a) 0:0 – no condition met b) 1:35 – condition met		

No	Field Name	Description	Required		Data Type	Length Type	Length (Min:Max)	Data Validations	Logic Validations
			Type	Condition Rule					
114	Person Paying Account Postal Address Line 2	Line 2 of the Postal address of Person Paying Account	O		FT	VAR	0:35		
115	Person Paying Account Postal Address Line 3	Line 3 of the Postal address of Person Paying Account	O		FT	VAR	0:35		
116	Person Paying Account Postal Address Line 4	Line 4 of the Postal address of Person Paying Account	O		FT	VAR	0:35		
117	Person Paying Account Postal Code	Postal code of the Person Paying Account	CW	If Person Paying Account Postal Address Line 1 is completed this field is mandatory	AN	VAR	a) 0:0 – no condition met b) 1:10 – condition met		
DEPENDANT DEMOGRAPHIC DATA (If Principal Member Number of Dependents Indicator >0; this record is mandatory)									
118	Section Identifier	To identify the start of the section as well as identifying the type of section	M		A	FIX	1:1	a) Must = B, where B = Body	
119	Record Type	Type of transaction	M		AN	VAR	1:6	a) Must = DDD, where DDD= Dependant Demographic Data	

No	Field Name	Description	Required		Data Type	Length Type	Length (Min:Max)	Data Validations	Logic Validations
			Type	Condition Rule					
120	Record Status	<p>The taxpayer's system must indicate whether a record is active, i.e. valid for the submission or must be cancelled from the submission</p> <p>Note: Record statuses that are deemed active are new, additions and corrections. Record statuses that are deemed cancelled are deletions.</p> <p>Indicates the status of the record, whether it is a new record, an adjusted record or a record that must be deleted</p>	M		A	FIX	1:1	<p>a) Must = A or C, where A = Active and C = Cancelled</p> <p>b)a) Record status can only be one of: N = New Record; C = Correction D= Delete record</p> <p>Note: The statuses must be used as follows:</p> <ul style="list-style-type: none"> • N – Indicate a new record that has not been submitted before; • C – Indicate that a previously submitted record is amended; • D – Indicate that a previously submitted record must be deleted. 	

No	Field Name	Description	Required		Data Type	Length Type	Length (Min:Max)	Data Validations	Logic Validations
			Type	Condition Rule					
121	Unique Number	The taxpayer's system must generate a unique number for each record. In the response file, the unique number would be the number specified in the file submitted to SARS to enable the submitting entity's source system to identify the line that is being responded on by SARS.	M		FT	VAR	1:100		a) Must be unique within the section across all files
122	Row Number	Number of the row in the file, sequential number starting at 1 for every file submitted to SARS. In the response file, this must be the rejected row(s) from the incoming file. The row number field must start at 1 for every new file and must increment by 1 for every new row added that is classed as a body record in the file. The last body record row number in the file must be equal to the total records supplied in the trailer. This would imply that for every file the body records start at 1 and increment by 1 for each record regardless of how many different sections there might be in the body, for files where there are multiple sections in the body.	M		N	VAR	1:10	a) An incrementing number per record beginning at 1 for each file b) Value must not contain a decimal point	a) Must be greater than or equal to 1 and smaller than or equal to the total number of rows in the file with Section Identifier = B

No	Field Name	Description	Required		Data Type	Length Type	Length (Min:Max)	Data Validations	Logic Validations
			Type	Condition Rule					
123	Unique Membership Number	Principal Member's unique membership number	M		AN	VAR	1:36		a) Must equal to a MED Unique Membership Number where Record Type = PMDD
124	MED Unique Number	Number is unique only to Principal Member (to be created and used IF membership number is not unique)	C	Mandatory if membership number is not unique	AN	VAR	1:36		a) Must equal to a MED Unique Number where Record Type = PMDD
125	Dependant Surname	Personal particulars – Surname of the individual	M		FT	VAR	1:120		
126	Dependant Initials	Personal particulars – Initials applicable only to individuals	MW	Mandatory for Individuals	FT	VAR	a) 0:0 - No condition met b) 1:30 - Condition met		
127	Dependant Names	Personal particulars – The first two name applicable only to individuals	M	Mandatory for Individuals	FT	VAR	a) 0:0 - No condition met b) 1:90 - Condition met	a) Names must be separated by a single space	
128	Dependant Identity Number	Personal particulars – South African Identify Number	C	At least one of the Dependant Identity number, Dependant Passport Number or Dependant Date of Birth fields must be completed for Individuals	N	FIX	a) 0:0 - No condition met b) 13:13 - Condition met	a) Identification number should not contain any special characters b) Refer to Appendix I for the ID validation that must be applied	Modulus test for identity number. Refer to section 7.2 Identification Number for the applicable modulus check

No	Field Name	Description	Required		Data Type	Length Type	Length (Min:Max)	Data Validations	Logic Validations
			Type	Condition Rule					
129	Dependant Passport Number	Passport number or other number (non-bar-coded RSA ID numbers) of the Dependant	C	At least one of the Dependant Identity number, Dependant Passport Number or Dependant Date of Birth fields must be completed for Individuals	AN	VAR	a) 0:0 – no condition met b) 6:20 – condition met	No spaces are allowed	
130	Dependant Passport Country of Issue	Indicates the country that issued the passport	C	Mandatory if Passport Number has been completed	A	FIX	a) 0:0 – no condition met b) 2:2 – condition met	a) Refer to Appendix B for passport country of issue codes b) If this value = ZAF then Dependant Identity number must be completed	
131	Dependant Income Tax Reference Number	SARS assigned Income tax reference number - Personal particulars	O		N	FIX	a) 0:0 – if this field is blank b) 10:10 – if this field is completed	a) Refer to Appendix H	a) Modulus 10 check for IT reference number. Refer to section 7.1 Tax Reference Number for the applicable modulus check The first character can only be 0, 1, 2, 3, or 9

No	Field Name	Description	Required		Data Type	Length Type	Length (Min:Max)	Data Validations	Logic Validations
			Type	Condition Rule					
132	Dependant Date of Birth	Dependant date of birth	C	At least one Dependant Identity number, Dependant Passport Number or Dependant Date of Birth field must be completed for Individuals	NFT	FIX	a) 0:0 – no condition met b) 10:10 – condition met	a) Format CCYY-MM-DD b) Date must not be greater than the current date	
PRINCIPAL MEMBER FINANCIAL DATA									
133	Section Identifier	To identify the start of the section as well as identifying the type of section	M		A	Fixed	1:1	a) Must = B, where B = Body	
134	Record Type	Type of transaction	M		AN	VAR	1:6	a) Must = PMFD, where PMFD = Principal Member Financial Data	

No	Field Name	Description	Required		Data Type	Length Type	Length (Min:Max)	Data Validations	Logic Validations
			Type	Condition Rule					
135	Record Status	<p>The taxpayer's system must indicate whether a record is active, i.e. valid for the submission or must be cancelled from the submission</p> <p>Note: Record statuses that are deemed active are new, additions and corrections. Record statuses that are deemed cancelled are deletions.</p> <p>Indicates the status of the record, whether it is a new record, an adjusted record or a record that must be deleted</p>	M		A	FIX	1:1	<p>a) Must = A or C, where A = Active and C = Cancelled</p> <p>b) Record status can only be one of: N = New Record; C = Correction D = Delete record</p> <p>Note: The statuses must be used as follows:</p> <ul style="list-style-type: none"> N – Indicate a new record that has not been submitted before; C – Indicate that a previously submitted record is amended; D – Indicate that a previously submitted record must be deleted. 	

No	Field Name	Description	Required		Data Type	Length Type	Length (Min:Max)	Data Validations	Logic Validations
			Type	Condition Rule					
136	Unique Number	The taxpayer's system must generate a unique number for each record. In the response file, the unique number would be the number specified in the file submitted to SARS to enable the submitting entity's source system to identify the line that is being responded on by SARS	M		FT	VAR	1:100		Must be unique within the section across all files

No	Field Name	Description	Required		Data Type	Length Type	Length (Min:Max)	Data Validations	Logic Validations
			Type	Condition Rule					
137	Row Number	Number of the row in the file, sequential number starting at 1 for every file submitted to SARS. In the response file, this must be the rejected row(s) from the incoming file. The row number field must start at 1 for every new file and must increment by 1 for every new row added that is classed as a body record in the file. The last body record row number in the file must be equal to the total records supplied in the trailer. This would imply that for every file the body records start at 1 and increment by 1 for each record regardless of how many different sections there might be in the body, for files where there are multiple sections in the body	M			VAR	1:10	<ul style="list-style-type: none"> a) An incrementing number per record beginning at 1 for each file b) Value must not contain a decimal point 	<ul style="list-style-type: none"> a) Must be greater than or equal to 1 and smaller than or equal to the total number of rows in the file with Section Identifier = B

No	Field Name	Description	Required		Data Type	Length Type	Length (Min:Max)	Data Validations	Logic Validations
			Type	Condition Rule					
138	Unique Membership Number	Principal Member's unique membership number	M		AN	VAR	1:36		a) Must equal to a MED Unique Membership Number where Record Type = PMDD
139	MED Unique Number	Number is unique only to Principal Member (to be created and used IF membership number is not unique)	C	Mandatory if membership number is not unique	AN	VAR	1:36		a) Must equal to a MED Unique Number where Record Type = PMDD
162	Medical Fund Contributions Source Code	Source code for monthly medical fund contributions	M		N	FIX	4:4	Valid if in Appendix A : Medical Scheme Contributions Source Codes Table	

No	Field Name	Description	Required		Data Type	Length Type	Length (Min:Max)	Data Validations	Logic Validations
			Type	Condition Rule					
140	March Contributions	Total Rand value of contributions made for the month of March (including cents). Only standard membership contribution fees to be stipulated and no extra fees (e.g. vitality fees).	C	<ul style="list-style-type: none"> a) Mandatory if the Account Start-Date is before the end of that month. E.g. if the Start-Date is on the 31st of the month then that field for that month is mandatory b) Mandatory if the period start date is within this month c) Mandatory if the period end date is within this range 	N	VAR	<ul style="list-style-type: none"> a) 0:0 - No condition met b) 4:18 - Condition met 	<ul style="list-style-type: none"> a) If 1.00 or greater, no leading zeros allowed. If <1.00, there must be 1 zero before the decimal b) Must be greater than or equal to 0.00 and smaller than or equal to 999999999999.99 c) Must always have 2 values after the decimal point to denote cent d) No negative values allowed 	

No	Field Name	Description	Required		Data Type	Length Type	Length (Min:Max)	Data Validations	Logic Validations
			Type	Condition Rule					
141	April Contributions	Total Rand value of contributions made for the month of April (including cents). Only standard membership contribution fees to be stipulated and no extra fees (e.g. vitality fees).	C	<p>a) Mandatory if the Account Start-Date is before the end of that month. E.g. if the Start-Date is on the 31st of the month then that field for that month is mandatory</p> <p>b) Mandatory if the period start date is within this month</p> <p>c) Mandatory if the period end date is within this range</p>	N	VAR	<p>a) 0:0 - No condition met</p> <p>b) 4:18 - Condition met</p>	<p>a) If 1.00 or greater, no leading zeros allowed. If <1.00, there must be 1 zero before the decimal</p> <p>b) Must be greater than or equal to 0.00 and smaller than or equal to 999999999999.99</p> <p>c) Must always have 2 values after the decimal point to denote cent</p> <p>d) No negative values allowed</p>	

No	Field Name	Description	Required		Data Type	Length Type	Length (Min:Max)	Data Validations	Logic Validations
			Type	Condition Rule					
142	May Contributions	Total Rand value of contributions made for the month of May (including cents). Only standard membership contribution fees to be stipulated and no extra fees (e.g. vitality fees).	C	<ul style="list-style-type: none"> a) Mandatory if the Account Start-Date is before the end of that month. E.g. if the Start-Date is on the 31st of the month then that field for that month is mandatory b) Mandatory if the period start date is within this month c) Mandatory if the period end date is within this range 	N	VAR	<ul style="list-style-type: none"> a) 0:0 - No condition met b) 4:18 - Condition met 	<ul style="list-style-type: none"> a) If 1.00 or greater, no leading zeros allowed. If <1.00, there must be 1 zero before the decimal b) Must be greater than or equal to 0.00 and smaller than or equal to 999999999999.99 c) Must always have 2 values after the decimal point to denote cent d) No negative values allowed 	

No	Field Name	Description	Required		Data Type	Length Type	Length (Min:Max)	Data Validations	Logic Validations
			Type	Condition Rule					
143	June Contributions	Total Rand value of contributions made for the month of June (including cents). Only standard membership contribution fees to be stipulated and no extra fees (e.g. vitality fees).	C	<ul style="list-style-type: none"> a) Mandatory if the Account Start-Date is before the end of that month. E.g. if the Start-Date is on the 31st of the month then that field for that month is mandatory b) Mandatory if the period start date is within this month c) Mandatory if the period end date is within this range 	N	VAR	<ul style="list-style-type: none"> a) 0:0 - No condition met b) 4:18 - Condition met 	<ul style="list-style-type: none"> a) If 1.00 or greater, no leading zeros allowed. If <1.00, there must be 1 zero before the decimal b) Must be greater than or equal to 0.00 and smaller than or equal to 999999999999.99 c) Must always have 2 values after the decimal point to denote cent d) No negative values allowed 	

No	Field Name	Description	Required		Data Type	Length Type	Length (Min:Max)	Data Validations	Logic Validations
			Type	Condition Rule					
144	July Contributions	Total Rand value of contributions made for the month of July (including cents). Only standard membership contribution fees to be stipulated and no extra fees (e.g. vitality fees).	C	<ul style="list-style-type: none"> a) Mandatory if the Account Start-Date is before the end of that month. E.g. if the Start-Date is on the 31st of the month then that field for that month is mandatory b) Mandatory if the period start date is within this month c) Mandatory if the period end date is within this range 	N	VAR	<ul style="list-style-type: none"> a) 0:0 - No condition met b) 4:18 - Condition met 	<ul style="list-style-type: none"> a) If 1.00 or greater, no leading zeros allowed. If <1.00, there must be 1 zero before the decimal b) Must be greater than or equal to 0.00 and smaller than or equal to 999999999999.99 c) Must always have 2 values after the decimal point to denote cent d) No negative values allowed 	

No	Field Name	Description	Required		Data Type	Length Type	Length (Min:Max)	Data Validations	Logic Validations
			Type	Condition Rule					
145	August Contributions	Total Rand value of contributions made for the month of August (including cents). Only standard membership contribution fees to be stipulated and no extra fees (e.g. vitality fees).	C	<ul style="list-style-type: none"> a) Mandatory if the Account Start-Date is before the end of that month. E.g. if the Start-Date is on the 31st of the month then that field for that month is mandatory b) Mandatory if the period start date is within this month c) Mandatory if the period end date is within this range 	N	VAR	<ul style="list-style-type: none"> a) 0:0 - No condition met b) 4:18 - Condition met 	<ul style="list-style-type: none"> a) If 1.00 or greater, no leading zeros allowed. If <1.00, there must be 1 zero before the decimal b) Must be greater than or equal to 0.00 and smaller than or equal to 999999999999.99 c) Must always have 2 values after the decimal point to denote cent d) No negative values allowed 	

No	Field Name	Description	Required		Data Type	Length Type	Length (Min:Max)	Data Validations	Logic Validations
			Type	Condition Rule					
146	September Contributions	Total Rand value of contributions made for the month of September (including cents). Only standard membership contribution fees to be stipulated and no extra fees (e.g. vitality fees).	C	<p>a) Mandatory if the Account Start-Date is before the end of that month. E.g. if the Start-Date is on the 31st of the month then that field for that month is mandatory</p> <p>b) Mandatory if the period start date is within this month</p> <p>c) Mandatory if the period end date is within this range</p>	N	VAR	<p>a) 0:0 - No condition met</p> <p>b) 4:18 - Condition met</p>	<p>a) If 1.00 or greater, no leading zeros allowed. If <1.00, there must be 1 zero before the decimal</p> <p>b) Must be greater than or equal to 0.00 and smaller than or equal to 999999999999.99</p> <p>c) Must always have 2 values after the decimal point to denote cent</p> <p>d) No negative values allowed</p>	

No	Field Name	Description	Required		Data Type	Length Type	Length (Min:Max)	Data Validations	Logic Validations
			Type	Condition Rule					
147	October Contributions	Total Rand value of contributions made for the month of October (including cents). Only standard membership contribution fees to be stipulated and no extra fees (e.g. vitality fees).	C	<p>a) Mandatory if the Account Start-Date is before the end of that month. E.g. if the Start-Date is on the 31st of the month then that field for that month is mandatory</p> <p>b) Mandatory if the period start date is within this month</p> <p>c) Mandatory if the period end date is within this range</p>	N	VAR	<p>a) 0:0 - No condition met</p> <p>b) 4:18 - Condition met</p>	<p>a) If 1.00 or greater, no leading zeros allowed. If <1.00, there must be 1 zero before the decimal</p> <p>b) Must be greater than or equal to 0.00 and smaller than or equal to 999999999999.99</p> <p>c) Must always have 2 values after the decimal point to denote cent</p> <p>d) No negative values allowed</p>	

No	Field Name	Description	Required		Data Type	Length Type	Length (Min:Max)	Data Validations	Logic Validations
			Type	Condition Rule					
148	November Contributions	Total Rand value of contributions made for the month of November (including cents). Only standard membership contribution fees to be stipulated and no extra fees (e.g. vitality fees).	C	<p>a) Mandatory if the Account Start-Date is before the end of that month. E.g. if the Start-Date is on the 31st of the month then that field for that month is mandatory</p> <p>b) Mandatory if the period start date is within this month</p> <p>c) Mandatory if the period end date is within this range</p>	N	VAR	<p>a) 0:0 - No condition met</p> <p>b) 4:18 - Condition met</p>	<p>a) If 1.00 or greater, no leading zeros allowed. If <1.00, there must be 1 zero before the decimal</p> <p>b) Must be greater than or equal to 0.00 and smaller than or equal to 999999999999.99</p> <p>c) Must always have 2 values after the decimal point to denote cent</p> <p>d) No negative values allowed</p>	

No	Field Name	Description	Required		Data Type	Length Type	Length (Min:Max)	Data Validations	Logic Validations
			Type	Condition Rule					
149	December Contributions	Total Rand value of contributions made for the month of December (including cents). Only standard membership contribution fees to be stipulated and no extra fees (e.g. vitality fees).	C	<p>a) Mandatory if the Account Start-Date is before the end of that month. E.g. if the Start-Date is on the 31st of the month then that field for that month is mandatory</p> <p>b) Mandatory if the period start date is within this month</p> <p>c) Mandatory if the period end date is within this range</p>	N	VAR	<p>a) 0:0 - No condition met</p> <p>b) 4:18 - Condition met</p>	<p>a) If 1.00 or greater, no leading zeros allowed. If <1.00, there must be 1 zero before the decimal</p> <p>b) Must be greater than or equal to 0.00 and smaller than or equal to 999999999999.99</p> <p>c) Must always have 2 values after the decimal point to denote cent</p> <p>d) No negative values allowed</p>	

No	Field Name	Description	Required		Data Type	Length Type	Length (Min:Max)	Data Validations	Logic Validations
			Type	Condition Rule					
150	January Contributions	Total Rand value of contributions made for the month of January (including cents). Only standard membership contribution fees to be stipulated and no extra fees (e.g. vitality fees).	C	<p>a) Mandatory if the Account Start-Date is before the end of that month. E.g. if the Start-Date is on the 31st of the month then that field for that month is mandatory</p> <p>b) Mandatory if the period start date is within this month</p> <p>c) Mandatory if the period end date is within this range</p>	N	VAR	<p>a) 0:0 - No condition met</p> <p>b) 4:18 - Condition met</p>	<p>a) If 1.00 or greater, no leading zeros allowed. If <1.00, there must be 1 zero before the decimal</p> <p>b) Must be greater than or equal to 0.00 and smaller than or equal to 999999999999.99</p> <p>c) Must always have 2 values after the decimal point to denote cent</p> <p>d) No negative values allowed</p>	

No	Field Name	Description	Required		Data Type	Length Type	Length (Min:Max)	Data Validations	Logic Validations
			Type	Condition Rule					
151	February Contributions	Total Rand value of contributions made for the month of February (including cents). Only standard membership contribution fees to be stipulated and no extra fees (e.g. vitality fees).	C	<ul style="list-style-type: none"> a) Mandatory if the Account Start-Date is before the end of that month. E.g. if the Start-Date is on the 31st of the month then that field for that month is mandatory b) Mandatory if the period start date is within this month c) Mandatory if the period end date is within this range 	N	VAR	<ul style="list-style-type: none"> a) 0:0 - No condition met b) 4:18 - Condition met 	<ul style="list-style-type: none"> a) If 1.00 or greater, no leading zeros allowed. If <1.00, there must be 1 zero before the decimal b) Must be greater than or equal to 0.00 and smaller than or equal to 999999999999999999.99 c) Must always have 2 values after the decimal point to denote cent d) No negative values allowed 	

No	Field Name	Description	Required		Data Type	Length Type	Length (Min:Max)	Data Validations	Logic Validations
			Type	Condition Rule					
163	Total medical fund contributions amount	Total monthly contributions made by the principal member for the current tax year	M		N	VAR	a) 4:18	<p>a) If 1.00 or greater, no leading zeros allowed. If <1.00, there must be 1 zero before the decimal</p> <p>b) Must be greater than or equal to 0.00 and smaller than or equal to 999999999999.99</p> <p>c) Must always have 2 values after the decimal point to denote cent</p>	Sum of all monthly contributions (field 140 to field 151)
164	Benefits not covered - tax allowable source code	Source code for benefits not covered - tax allowable	O		N	FIX	4:4	Valid if in Appendix A: Medical Scheme Contributions Source Codes Table	

No	Field Name	Description	Required		Data Type	Length Type	Length (Min:Max)	Data Validations	Logic Validations
			Type	Condition Rule					
152	Benefits not covered - tax allowable amount	Benefits not covered by the scheme for income tax purposes	C	Mandatory if benefits not covered - tax allowable source code is completed	N	VAR	a) 4:18	<p>a) If 1.00 or greater, no leading zeros allowed. If <1.00, there must be 1 zero before the decimal</p> <p>b) Must be greater than or equal to 0.00 and smaller than or equal to 999999999999.99</p> <p>c) Must always have 2 values after the decimal point to denote cent</p>	

No	Field Name	Description	Required		Data Type	Length Type	Length (Min:Max)	Data Validations	Logic Validations
			Type	Condition Rule					
153	Benefits not covered-special amount	Benefits not covered by the scheme for special dependants	O		N	VAR	4:18	<p>a) If 1.00 or greater, no leading zeros allowed. If <1.00, there must be 1 zero before the decimal</p> <p>b) Must be greater than or equal to 0.00 and smaller than or equal to 999999999999.99</p> <p>c) Must always have 2 values after the decimal point to denote cent</p>	
165	Monthly Capped Amount Source Code	Source code for monthly capped amount	O		N	FIX	4:4	<p>a) Valid if in Appendix A: Medical Scheme Contributions Source Codes Table</p>	<p>c) Only applicable until end Feb 2010.</p>

No	Field Name	Description	Required		Data Type	Length Type	Length (Min:Max)	Data Validations	Logic Validations
			Type	Condition Rule					
154	Monthly Capped Amount	Capped monthly amount in respect of tax deductions	C	Mandatory if monthly capped amount source code is completed	N	VAR	a) 4:18	<p>a) If 1.00 or greater, no leading zeros allowed. If <1.00, there must be 1 zero before the decimal</p> <p>b) Must be greater than or equal to 0.00 and smaller than or equal to 999999999999.99</p> <p>c) Must always have 2 values after the point to denote cent</p>	a) Only applicable until end Feb 2010.
166	Interest on Savings Source Code	Source code for interest on savings	O		N	FIX	4:4	<p>a) Valid if in Appendix A: Medical Scheme Contributions Source Codes Table</p>	

No	Field Name	Description	Required		Data Type	Length Type	Length (Min:Max)	Data Validations	Logic Validations
			Type	Condition Rule					
155	Interest on Savings Amount	Interest on savings plans	C	Mandatory if interest on savings source code is completed	N	VAR	a) 4.18	<p>a) If 1.00 or greater, no leading zeros allowed. If <1.00, there must be 1 zero before the decimal</p> <p>b) Must be greater than or equal to 0.00 and smaller than or equal to 999999999999.99</p> <p>c) Must always have 2 values after the decimal point to denote cent</p>	

No	Field Name	Description	Required		Data Type	Length Type	Length (Min:Max)	Data Validations	Logic Validations
			Type	Condition Rule					
156	Refunds	Savings plans refunds to members	O	a)	N		a) 4:18	a) If 1.00 or greater, no leading zeros allowed. If <1.00, there must be 1 zero before the decimal b) Must be greater than or equal to 0.00 and smaller than or equal to 999999999999.99 c) Must always have 2 values after the decimal point to denote cent	
FILE TRAILER									
157	Section Identifier	To identify the start of the section as well as identifying the type of section.	M		A	Fixed	1:1	Must = "T"	
158	Total Number of Records	This is the sum of all records contained in the body of the delimited file. This sum excludes the header and the trailer records.	M		N	VAR	1:15	Value must not contain a decimal	a) Must be greater than or equal to 1 and less than or equal to 999999999999 b) Must be equal to the total of all lines with a section identifier of B

No	Field Name	Description	Required		Data Type	Length Type	Length (Min:Max)	Data Validations	Logic Validations
			Type	Condition Rule					
159	File Hash Total	<p>Calculation based on all the characters in the file. Must use MD5 calculation.</p> <p>Note – If you do not provide this field, the file will be accepted with warning, however SARS will not be able to confirm the integrity of the contents of the file submitted.</p>	MW		AN	FIX	32:32		<p>a) Must use MD5 calculation</p> <p>b) Use all sections, except those where the section identifier = T.</p> <p>c) File hash total calculation must equal this field value</p>

6.2 File Layout: 2. Response

The table below lists all the fields that are required for the file containing the response to supporting data files submitted to SARS. The table specifies for each field, the required length, provides a description and also indicates the relevant validation rules.

Note: The number column is used to reference fields in the table for ease of use in this specification document.

Below is the layout of the PSV response file header that is submitted from SARS to the taxpayer.

No	Field Name	Description	Required		Data Type	Length Type	Length (Min:Max)	Data Validations	Logic Validations
			Type	Condition Rule					
REQUEST / RESPONSE FILE HEADER									
1	Section Identifier	To identify the start of the section as well as identifying the type of section	M		A	FIX	1:1	a) Must = H, where H = Header	
2	Header Type	To indicate the type of header in order to differentiate between various types	M		A	FIX	1:3	a) Must = GH, where GH = General Header	
3	Message Create Date	Date and time that the message was created	M			FIX	19:19	a) Format must be: CCYY-MM-DDThh:mm:ss b) 24h time format must be used	a) Must be less than or equal to today's date
4	File Layout Version	The version of the delimited file layout that is being submitted. Sequential number, which increments with one every time that the file layout version changes once file is being submitted to the production environment. This number is provided by SARS	M		N	VAR	1:4	a) Must = 1 b) Value must not contain a decimal point Note – SARS will only support the version(s) specified above	a) Must be greater than or equal to 1 and less than or equal to 9999

No	Field Name	Description	Required		Data Type	Length Type	Length (Min:Max)	Data Validations	Logic Validations
			Type	Condition Rule					
5	Unique File ID	The submitting source must create this field when data is submitted to SARS. This field will uniquely identify this file when coupled with the source. This value must not be repeated by the submitting source (e.g. use the date time with some other unique number). This field will also be used to link the records to the original file. The field must be generated by the software from which the entity is submitting the data to SARS. When SARS sends the response file, the Unique File ID in the response file must be equal to the Unique File ID obtained from the file name of the submitted file	C	a) If File Response Code = 001, 002, 003, 004, 005, 006, 011 or 012 then this field is mandatory	AN	VAR	a) 0:0 – No condition met b) 1:64 – Condition met	a) Value must not contain a decimal point	a) Must equal the Unique File ID of the submitted file
6	SARS Request Reference	In the scenario where SARS sends a request file to the entity requesting data, SARS provides this reference number to use in the file to be submitted to SARS. SARS also uses this reference number when responding to the taxpayer on files submitted to SARS	C	a) If Data Type Being Supplied = MED, then this field must be left blank	AN	VAR	a) 0:0 – If field is left blank b) 1:64 – If field is complete		

No	Field Name	Description	Required		Data Type	Length Type	Length (Min:Max)	Data Validations	Logic Validations
			Type	Condition Rule					
7	Test Data Indicator	This should be used to indicate if the data is for testing or is live data and should be processed. The purpose of the field is to avoid test data accidentally being processed in production and allow the source to test their submission without it being processed. Note – If SARS receives a value = T in the production environment or a value = L in the test environment, then the file will be rejected in its entirety	M		A	FIX	a) 1:1	a) a) Must = T or L, where T = Test and L = Live	
8	Data Type Being Supplied	When data is submitted to SARS, this field indicates the type of data that can be found in the file, e.g. Dividends tax, VAT supporting data. When SARS sends a response on a file submitted, SARS uses the Data_Type_Being_Supplied from the file name of the file submitted to SARS	C	a) If File Response Code = 001, 002, 003, 004, 005, 006, 011 or 012 then this field is mandatory	AN	FIX	a) 0:0 – No condition met b) 3:3 – Condition met	a) Must = MED, where MED = Medical scheme contributions extracts data	
9	Source Identifier	This identifies the file submitter and contains the security token. This value will be supplied by SARS	C	a) If File Response Code = 001, 003, 004, 005, 006, 011 or 012 then this field is mandatory	AN	FIX	a) 0:0 – no condition met b) 144:144 – condition met		a) Validate that this value = the value supplied by SARS

No	Field Name	Description	Required		Data Type	Length Type	Length (Min:Max)	Data Validations	Logic Validations
			Type	Condition Rule					
10	Group ID	If the amount of data requires that it be sent in multiple files, a unique Group ID must be created on the submitting entity's system to be able to link the multiple files to the one group	C	a) If File Response Code = 001, 003, 004, 005, 006, or 012 then this field is mandatory	AN	VAR	a) 0:0 – no condition met b) 1:64 – condition met		
11	Group Total	Number of files that make up a group, e.g. if the amount of data requires three files to be submitted, then the Group Total must be 3. For example, where it is required for data to be submitted in one file and the file is too large to accommodate the submission in a single file, the file can be split into smaller more manageable files and this field must then indicate the total number of files that make up the submission	C	a) If File Response Code = 001, 003, 004, 005, 006, or 012 then this field is mandatory	N	VAR	a) 0:0 – no condition met b) 1:4 – condition met	a) Value must not contain a decimal point	a) Must be greater than or equal to 1 and less than or equal to 9999
12	Unique Group Item ID	The number of this file in the group. This number must be an incrementing number beginning at one for each group submission, and incrementing by 1 for each file in the group. E.g. if this is the second file of the group this field must be 2	C	a) If File Response Code = 001, 003, 004, 005, 006, or 012 then this field is mandatory	N	VAR	a) 0:0 – no condition met b) 1:4 – condition met	a) Value must not contain a decimal point	a) Must be equal or greater than 1 b) Must be less than or equal to the Group Total c) Must be submitted in sequence

No	Field Name	Description	Required		Data Type	Length Type	Length (Min:Max)	Data Validations	Logic Validations
			Type	Condition Rule					
13	File Response Code	This is the status for the entire submitted file, reflecting the result of technical and business validations performed on the incoming file	M		N	FIX	3:3	a) Must = 001, 002, 003, 004, 005 or 006, 011 or 012 Refer to Appendix D for the list of codes Note: Refer to section 5 General Rules for Import File Structures for the detailed error messages	
14	File Response Reason	The reason why the file was rejected in its entirety	C	a) If File Response Code is equal to 005 this field is mandatory	FT	VAR	a) 0:0 – No condition met b) 1:100 – Condition met		
15	Transaction Date	The date for which data is required	C	a) If Data Type Being Supplied = MED the field must be left blank					
16	Tax Period	This is the period for which data is required	C	a) If Data Type Being Supplied = MED, the field must be left blank					
17	Transaction Year	The transaction year for which the data is required	O		N		a) 0:0 – if this field is blank b) 4:4– if this field is completed	a) Format CCYY	a) Must be greater than or equal to 1900 and less than or equal to current year

No	Field Name	Description	Required		Data Type	Length Type	Length (Min:Max)	Data Validations	Logic Validations
			Type	Condition Rule					
18	SLA Requirement Date	This is the date by which the taxpayer has to submit the required data	C	a) If Data Type Being Supplied = MED, the field must be left blank	FT	FIX	a) 0:0 – if this field is blank b) 10:10– if this field is complete d		
REQUEST / RESPONSE FILE BODY (This section must only be completed if File Response Code = 004, 005 or 006)									
19	Section Identifier	To identify the start of the section as well as identifying the type of section.	M		A	FIX	1:1	a) Must = B, where B = Body	
20	Row Number	Number of the row in the file, sequential number starting at 1 for every file submitted to SARS. In the response file, this must be the rejected row(s) from the incoming file. The row number field must start at 1 for every new file and must increment by 1 for every new row added that is classed as a body record in the file. The last body record row number in the file must be equal to the total records supplied in the trailer. This would imply that for every file the body records start at 1 and increment by 1 for each record regardless of how many different sections there might be in the body, for files where there are multiple sections in the body	M		N	VAR	1:10	a) Value must not contain a decimal point	a) Must be greater than or equal to 1 and less than or equal to 9999999999 b) If the Section Identifier of the section within which the record from the submission file resides is not equal to "B", the Row Number must = zero (0). c) c) If the Section Identifier of the section within which the record from the submission file = "B", the Row Number must equal the Row Number of the record to be responded on from the submission file

No	Field Name	Description	Required		Data Type	Length Type	Length (Min:Max)	Data Validations	Logic Validations
			Type	Condition Rule					
21	Unique Number	<p>The taxpayer's system must generate a unique number for each record.</p> <p>In the response file, the unique number would be the number specified in the file submitted to SARS to enable the submitting entity's source system to identify the line that is being responded on by SARS.</p>	M		FT	VAR	1:100		<p>a) If the Section Identifier of the section within which the record from the submission file resides is not equal to "B" and not equal to "T", the Unique Number must contain the value contained in the corresponding Header Type field, e.g. "GH" or "SE"</p> <p>b) If the Section Identifier of the section within which the record from the submission file resides is equal to "T", the Unique Number must equal "T"</p> <p>c) If the Section Identifier of the section within which the record from the submission file = "B", the Unique Number must equal the Unique Number of the record to be responded on from the submission file</p>

No	Field Name	Description	Required		Data Type	Length Type	Length (Min:Max)	Data Validations	Logic Validations
			Type	Condition Rule					
22	Field Name	For fields that are rejected or accepted with a warning, this field must display the field that failed validation	C	a) If Response Code = 001, 002, 003, 004, 005 or 006, this field is mandatory	FT	VAR	a) 0:0 – No condition met b) 1:100 – Condition met		
23	Overall Field Status	To indicate the status of the field as specified per data type. A field may be rejected or accepted with warning	C	a) If Field Name contains a value, this field is mandatory	A		a) 0:0 – No condition met b) 1:1 – Condition met	a) Must = R or W, where R = Rejected and W = Accepted with a warning	
24	Response Code	Indicating the status of a field after validations were applied	M		AN	FIX	3:3	a) Must = 001, 002, 003, 004, 005, 006 or 500 Refer to Appendix E for the list of codes	
25	Response Reason	For fields that are rejected or accepted with a warning, this field must display the reason for the failed validation	M		FT	VAR	1:300		
26	Field Value	For fields that are rejected or accepted with a warning, this field must display the value of the field that was submitted to SARS.	C	a) If Start Range and End Range is empty and if Response Code contains a value, this field is mandatory	FT	VAR	a) 0:0 – No condition met b) 1:120 – Condition met		

No	Field Name	Description	Required		Data Type	Length Type	Length (Min:Max)	Data Validations	Logic Validations
			Type	Condition Rule					
27	Start Range	Where the response applies to multiple lines, this field will indicate the start of the range of applicable rows.	C	a) If the Response Code, Field Name and Response Reason repeat for more than 10 sequential rows, this field is mandatory	N	VAR	a) 0:0 – No condition met b) 1:10 – Condition met	c) Value must not contain a decimal point	a) Must be greater than or equal to 1 and less than or equal to 9999999999
28	End Range	Where the response applies to multiple lines, this field will indicate the end of the range of applicable rows.	C	a) If the Response Code, Field Name and Response Reason repeat for more than 10 sequential rows, this field is mandatory	N	VAR	a) 0:0 – No condition met b) 1:10 – Condition met	c) Value must not contain a decimal point	a) Must be greater than or equal to 1 and less than or equal to 9999999999
REQUEST / RESPONSE FILE TRAILER (This section must only be completed if File Response Code = 004, 005 or 006)									
29	Section Identifier	To identify the start of the section as well as identifying the type of section.	M		A	FIX	1:1	a) Must = T, where T = Trailer	
30	Total Number of Records	This is the sum of all records contained in the body of the delimited file. This sum excludes the header and the trailer records	M		N	VAR	1:15	c) Value must not contain a decimal point	a) Must be greater than or equal to 1 and less than or equal to 9999999999 b) Must be equal to the total of all lines with a section identifier of B

No	Field Name	Description	Required		Data Type	Length Type	Length (Min:Max)	Data Validations	Logic Validations
			Type	Condition Rule					
31	File Hash Total	Calculation based on all the characters in the file. Must use MD5 calculation.	M		AN	FIX	32:32		<ul style="list-style-type: none"> a) Must use MD5 calculation b) Use all sections, except where Section Identifier = T c) File hash total calculation must equal this field value

7. REFERENCE TABLES

7.1 Appendix A: Medical Scheme Contributions Source Codes Table

Code	Description
4005	Medical Fund Contributions
4020	Benefits Not Covered Tax Allowable
4486	Monthly Capped Amount
4201	Interest on Savings Plan

7.2 Appendix B: Codes for the Country that issued the Passport

The Country Codes are aligned with the ISO3166 standard.

Code	Description	Code	Description	Code	Description
AF	AFGHANISTAN	GH	GHANA	OM	OMAN
AX	ÅLAND ISLANDS	GI	GIBRALTAR	PK	PAKISTAN
AL	ALBANIA	GR	GREECE	PW	PALAU
DZ	ALGERIA	GL	GREENLAND	PS	PALESTINE, STATE OF
AS	AMERICAN SAMOA	GD	GRENADA	PA	PANAMA
AD	ANDORRA	GP	GUADELOUPE	PG	PAPUA NEW GUINEA
AO	ANGOLA	GU	GUAM	PY	PARAGUAY
AI	ANGUILLA	GT	GUATEMALA	PE	PERU
AQ	ANTARCTICA	GG	GUERNSEY	PH	PHILIPPINES
AG	ANTIGUA AND BARBUDA	GN	GUINEA	PN	PITCAIRN
AR	ARGENTINA	GW	GUINEA-BISSAU	PL	POLAND
AM	ARMENIA	GY	GUYANA	PT	PORTUGAL
AW	ARUBA	HT	HAITI	PR	PUERTO RICO
AU	AUSTRALIA	HM	HEARD ISLAND AND MCDONALD ISLANDS	QA	QATAR
AT	AUSTRIA	VA	HOLY SEE (VATICAN CITY STATE)	RE	RÉUNION
AZ	AZERBAIJAN	HN	HONDURAS	RO	ROMANIA
BS	BAHAMAS	HK	HONG KONG	RU	RUSSIAN FEDERATION
BH	BAHRAIN	HU	HUNGARY	RW	RWANDA
BD	BANGLADESH	IS	ICELAND	BL	SAINT BARTHÉLEMY
BB	BARBADOS	IN	INDIA	SH	SAINT HELENA, ASCENSION AND TRISTAN DA CUNHA
BY	BELARUS	ID	INDONESIA	KN	SAINT KITTS AND NEVIS
BE	BELGIUM	IR	IRAN, ISLAMIC REPUBLIC OF	LC	SAINT LUCIA
BZ	BELIZE	IQ	IRAQ	MF	SAINT MARTIN (FRENCH PART)
BJ	BENIN	IE	IRELAND	PM	SAINT PIERRE AND MIQUELON
BM	BERMUDA	IM	ISLE OF MAN	VC	SAINT VINCENT AND THE GRENADINES
BT	BHUTAN	IL	ISRAEL	WS	SAMOA
BO	BOLIVIA, PLURINATIONAL STATE OF	IT	ITALY	SM	SAN MARINO
BQ	BONAIRE, SINT EUSTATIUS AND SABA	JM	JAMAICA	ST	SAO TOME AND PRINCIPE
BA	BOSNIA AND HERZEGOVINA	JP	JAPAN	SA	SAUDI ARABIA
BW	BOTSWANA	JE	JERSEY	SN	SENEGAL
BV	BOUVET ISLAND	JO	JORDAN	RS	SERBIA

Code	Description	Code	Description	Code	Description
BR	BRAZIL	KZ	KAZAKHSTAN	SC	SEYCHELLES
IO	BRITISH INDIAN OCEAN TERRITORY	KE	KENYA	SL	SIERRA LEONE
BN	BRUNEI DARUSSALAM	KI	KIRIBATI	SG	SINGAPORE
BG	BULGARIA	KP	KOREA, DEMOCRATIC PEOPLE'S REPUBLIC OF	SX	SINT MAARTEN (DUTCH PART)
BF	BURKINA FASO	KR	KOREA, REPUBLIC OF	SK	SLOVAKIA
BI	BURUNDI	KW	KUWAIT	SI	SLOVENIA
KH	CAMBODIA	KG	KYRGYZSTAN	SB	SOLOMON ISLANDS
CM	CAMEROON	LA	LAO PEOPLE'S DEMOCRATIC REPUBLIC	SO	SOMALIA
CA	CANADA	LV	LATVIA	ZA	SOUTH AFRICA
CV	CAPE VERDE	LB	LEBANON	GS	SOUTH GEORGIA AND THE SOUTH SANDWICH ISLANDS
KY	CAYMAN ISLANDS	LS	LESOTHO	SS	SOUTH SUDAN
CF	CENTRAL AFRICAN REPUBLIC	LR	LIBERIA	ES	SPAIN
TD	CHAD	LY	LIBYA	LK	SRI LANKA
CL	CHILE	LI	LIECHTENSTEIN	SD	SUDAN
CN	CHINA	LT	LITHUANIA	SR	SURINAME
CX	CHRISTMAS ISLAND	LU	LUXEMBOURG	SJ	SVALBARD AND JAN MAYEN
CC	COCOS (KEELING) ISLANDS	MO	MACAO	SZ	SWAZILAND
CO	COLOMBIA	MK	MACEDONIA, THE FORMER YUGOSLAV REPUBLIC OF	SE	SWEDEN
KM	COMOROS	MG	MADAGASCAR	CH	SWITZERLAND
CG	CONGO	MW	MALAWI	SY	SYRIAN ARAB REPUBLIC
CD	CONGO, THE DEMOCRATIC REPUBLIC OF THE	MY	MALAYSIA	TW	TAIWAN, PROVINCE OF CHINA
CK	COOK ISLANDS	MV	MALDIVES	TJ	TAJIKISTAN
CR	COSTA RICA	ML	MALI	TZ	TANZANIA, UNITED REPUBLIC OF
CI	CÔTE D'IVOIRE	MT	MALTA	TH	THAILAND
HR	CROATIA	MH	MARSHALL ISLANDS	TL	TIMOR-LESTE
CU	CUBA	MQ	MARTINIQUE	TG	TOGO
CW	CURAÇAO	MR	MAURITANIA	TK	TOKELAU
CY	CYPRUS	MU	MAURITIUS	TO	TONGA
CZ	CZECH REPUBLIC	YT	MAYOTTE	TT	TRINIDAD AND TOBAGO
DK	DENMARK	MX	MEXICO	TN	TUNISIA

Code	Description	Code	Description	Code	Description
DJ	DJIBOUTI	FM	MICRONESIA, FEDERATED STATES OF	TR	TURKEY
DM	DOMINICA	MD	MOLDOVA, REPUBLIC OF	TM	TURKMENISTAN
DO	DOMINICAN REPUBLIC	MC	MONACO	TC	TURKS AND CAICOS ISLANDS
EC	ECUADOR	MN	MONGOLIA	TV	TUVALU
EG	EGYPT	ME	MONTENEGRO	UG	UGANDA
SV	EL SALVADOR	MS	MONTSERRAT	UA	UKRAINE
GQ	EQUATORIAL GUINEA	MA	MOROCCO	AE	UNITED ARAB EMIRATES
ER	ERITREA	MZ	MOZAMBIQUE	GB	UNITED KINGDOM
EE	ESTONIA	MM	MYANMAR	US	UNITED STATES
ET	ETHIOPIA	NA	NAMIBIA	UM	UNITED STATES MINOR OUTLYING ISLANDS
FK	FALKLAND ISLANDS (MALVINAS)	NR	NAURU	UY	URUGUAY
FO	FAROE ISLANDS	NP	NEPAL	UZ	UZBEKISTAN
FJ	FIJI	NL	NETHERLANDS	VU	VANUATU
FI	FINLAND	NC	NEW CALEDONIA	VE	VENEZUELA, BOLIVARIAN REPUBLIC OF
FR	FRANCE	NZ	NEW ZEALAND	VN	VIET NAM
GF	FRENCH GUIANA	NI	NICARAGUA	VG	VIRGIN ISLANDS, BRITISH
PF	FRENCH POLYNESIA	NE	NIGER	VI	VIRGIN ISLANDS, U.S.
TF	FRENCH SOUTHERN TERRITORIES	NG	NIGERIA	WF	WALLIS AND FUTUNA
GA	GABON	NU	NIUE	EH	WESTERN SAHARA
GM	GAMBIA	NF	NORFOLK ISLAND	YE	YEMEN
GE	GEORGIA	MP	NORTHERN MARIANA ISLANDS	ZM	ZAMBIA
DE	GERMANY	NO	NORWAY	ZW	ZIMBABWE
				XX	OTHER

7.3 Appendix C: Identification Type Code Table

Code	Description
001	South African ID number
002	Foreign ID number
003	Foreign Passport number
004	South African company/ close corporation registration number
005	Foreign company registration number
006	ISIN number
007	South African trust registration number
008	Foreign trust registration number
009	Internal identification number
010

7.4 Appendix D: File Response Codes

Code	Description
001	Acknowledgement of receipt
002	Rejected: entire file rejected as contains critical errors. The file must be corrected and resubmitted to enable processing
003	Successfully uploaded: all records accepted and processed.
004	Accepted with warnings: This can be any combination of accepted fields, fields accepted with a warning and duplicate records.
005	Rejected: entire file rejected as it contains file structure errors. The file must be corrected and resubmitted to enable processing.
006	Partial upload: This can be any combination of accepted fields, rejected fields, fields accepted with a warning or duplicate records.
011	Rejected: entire file rejected as the file was submitted as part of a group and one or more of the files in the group failed the validations associated with the submission of a file as part of a group.
012	Rejected: Group submission incomplete and service level agreement expired for SARS to wait for all files in a group to be submitted.

7.5 Appendix E: Response Codes

Code	Description
001	Mandatory field left blank – Mandatory field does not contain a value.
002	Incorrect field length – Field length does not comply with the specification.
003	Incorrect field format – Field format does not comply with the specification.
004	Invalid field value – Field can only have a defined set of values. The value supplied in the field does not appear in the defined set of values.
005	Invalid Logic – Field value does not meet a logic rule i.e. A + B must be equal to this field or Field does not pass Mod 10 test
006	SARS System Rejection – Field failed because it does not meet a data or business rule requirement within a SARS system i.e. Tax Reference number does not exist
500	Duplicate Record already existing

7.6 Appendix F: Nature of Person

Code	Description
INDIVIDUAL	Individual
FOREIGN_INDIVIDUAL	Foreign Individual
INDIVIDUAL_ESTATE	Individual Estates (including late Estates)
PARTNERSHIP	Partnerships
PUBLIC_CO	Listed company
PRIVATE_CO	Unlisted company
CLOSE_CORPORATION	Close Corporation
FOREIGN_COMPANY	Foreign Company
OTHER_CO	Other Company
CORP_ESTATE	Corporate: Estate/Liquidation
INTERVIVOS_TRUST	Trust (any type)
GOVERNMENT_ENTITY	RSA Government, Provincial Administration, Municipalities
RETIREMENT_FUND	Retirement Fund (Pension, Provident, Benefit, RA etc.)
CLUB	Clubs
UNINCORPORATED_BODY_OF_PERSONS	Other entity not covered by the list provided (including a portfolio of a Collective Investment Scheme in Securities)
ASSOC_NOT_FOR_GAIN	Association not for gain
STOKVEL	Stokvel
SOCIETY	Society

7.7 Appendix G – Company registration number validation

CCYY/NNNNNN/NN, where the CCYY must be validated to be from 1800 and up and including the current calendar year. The last two digits of this number must be validated to be either of the following: 06, 07, 08, 09, 10, 11, 20, 21, 22, 23, 24, 25, 26, 30, 31

7.8 Appendix H: Tax Reference Number (Modulus 10 Validation)

The odd positioned digits of the tax reference number (1, 3, 5, 7 and 9) are multiplied by 2. If the answer is greater than 10 the digits are added together to get the calculated value. Add these calculated values and the even positioned digits of the Tax reference number (2, 4, 6 and 8) together. Subtract the last character of this calculation from 10 to get the check digit. If this is not equal to the last digit of the Tax reference number as entered, then this does not pass the modulus 10 test.

The last character is a check digit, calculated by applying the following algorithm:

Digit	Formula
Digit 1	Multiply by 2 (Add result to total)* See below
Digit 2	Add to total
Digit 3	Multiply by 2 (Add result to total)* See below
Digit 4	Add to total
Digit 5	Multiply by 2 (Add result to total)* See below
Digit 6	Add to total
Digit 7	Multiply by 2 (Add result to total)* See below
Digit 8	Add to total
Digit 9	Multiply by 2 (Add result to total)* See below

* When the result of the line item calculation exceeds 9, add the individual digits together to obtain a single digit result (e.g. $18 = 1 + 8 = 9$)

Digit 10: Check digit

If the last digit of Total > 0 Then

The Check Digit should be equal to the result of $10 - (\text{Total MOD } 10)$

If the last digit of Total = 0 Then

The Check Digit should be equal to zero

Example:

Tax Reference Number = 0001339050

Digit	Formula	Result
Digit 1	0×2	0
Digit 2	0	+ 0
Digit 3	0×2	+ 0
Digit 4	1	+ 1
Digit 5	3×2	+ 6
Digit 6	3	+ 3
Digit 7	$9 \times 2 = 18$ (1 + 8 = 9)	+ 9
Digit 8	0	+ 0
Digit 9	$5 \times 2 = 10$ (1 + 0 = 1)	+ 1
Total		20

Last Digit of Total is not greater than zero 0 so the check digit equal 0 and the number is therefore valid.

7.9 Appendix I: South African Identification Number

Even positions of the identification number (2, 4, 6, 8, 10, and 12) are multiplied by 2. If the answer is greater than 10 the digits are added together to get the calculated value. Add these calculated values and the odd positions of the identification number (1, 3, 5, 7, 9, and 11) together. Subtract the last character of this calculation from 10 to get the check digit. If this is not equal to the last character of the identification number as entered, then this does not pass the modulus 10 tests.

Format:

{YYMMDD}{G}{SSS}{C}{A}{Z}

YYMMDD : Date of birth.

G : Gender. 0-4 Female; 5-9 Male.

SSS : Sequence No. for DOB/G combination.

C : Citizenship. 0 SA; 1 Other.

A : Usually 8, or 9 [can be other values]

Z : Control digit

Formula to calculate the check digit for a 13 digit identity number:

According to the provisions of the Identification Amendment Act, 2000 (Act No. 28 of 2000, which was promulgated on 13 October 2000) all forms of identity documents other than the green bar-coded identity document are invalid. In accordance with the legislation, the control figure which is the 13th digit of all identity numbers which is calculated as follows using ID Number 800101 5009 087 as an example:

Add all the digits in the odd positions (excluding last digit). $8 + 0 + 0 + 5 + 0 + 0 = 13$[1]

Move the even positions into a field and multiply the number by 2.

$011098 \times 2 = 22196$

Add the digits of the result in b).

$2 + 2 + 1 + 9 + 6 = 20$[2]

Add the answer in [2] to the answer in [1].

$13 + 20 = 33$

Subtract the second digit (i.e. 3) from 10. The number must tally with the last number in the ID Number. If the result is 2 digits, the last digit is used to compare against the last number in the ID Number. If the answer differs, the ID number is invalid.

7.10 Appendix J: MD5 Calculation (File Hash Total)

The following calculation must be used for determining the file hash total.

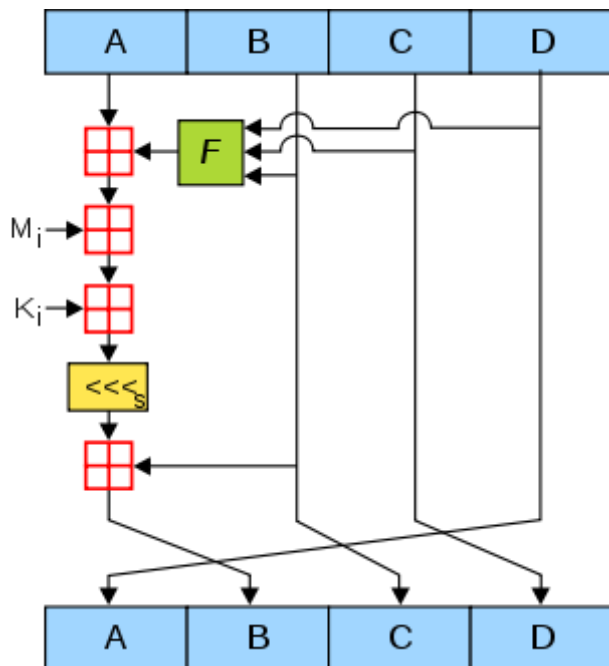

Figure 1. One MD5 operation. MD5 consists of 64 of these operations, grouped in four rounds of 16 operations. F is a nonlinear function; one function is used in each round. M_i denotes a 32-bit block of the message input, and K_{id} denotes a 32-bit constant, different for each operation. \lll_s denotes a left bit rotation by s places; s varies for each operation. \boxplus denotes addition modulo 2^{32} .

MD5 processes a VAR-length message into a FIX-length output of 128 bits. The input message is broken up into chunks of 512-bit blocks (sixteen 32-bit little endian integers); the message is padded so that its length is divisible by 512. The padding works as follows: first a single bit, 1, is appended to the end of the message. This is followed by as many zeros as are required to bring the length of the message up to 64 bits fewer than a multiple of 512. The remaining bits are filled up with a 64-bit little endian integer representing the length of the original message, in bits.

The main MD5 algorithm operates on a 128-bit state, divided into four 32-bit words, denoted A , B , C and D . These are initialized to certain FIX constants. The main algorithm then operates on each 512-bit message block in turn, each block modifying the state. The processing of a message block consists of four similar stages, termed *rounds*; each round is composed of 16 similar operations based on a non-linear function F , modular addition, and left rotation. Figure 1 illustrates one operation within a round. There are four possible functions F ; a different one is used in each round:

$$\begin{aligned}
 F(X, Y, Z) &= (X \wedge Y) \vee (\neg X \wedge Z) \\
 G(X, Y, Z) &= (X \wedge Z) \vee (Y \wedge \neg Z) \\
 H(X, Y, Z) &= X \oplus Y \oplus Z \\
 I(X, Y, Z) &= Y \oplus (X \vee \neg Z)
 \end{aligned}$$

\oplus , \wedge , \vee , \neg denote the XOR, AND, OR and NOT operations respectively.

The MD5 hash is calculated according to this algorithm:

//Note: All VARs are unsigned 32 bits and wrap modulo 2^{32} when calculating
varint[64] r, k

//r specifies the per-round shift amounts

r[0..15] := {7, 12, 17, 22, 7, 12, 17, 22, 7, 12, 17, 22, 7, 12, 17, 22}

r[16..31] := {5, 9, 14, 20, 5, 9, 14, 20, 5, 9, 14, 20, 5, 9, 14, 20}

r[32..47] := {4, 11, 16, 23, 4, 11, 16, 23, 4, 11, 16, 23, 4, 11, 16, 23}

r[48..63] := {6, 10, 15, 21, 6, 10, 15, 21, 6, 10, 15, 21, 6, 10, 15, 21}

//Use binary integer part of the sines of integers (Radians) as constants:

forfrom 0 to 63

k[i] := floor(abs(sin(i + 1)) × (2 pow 32))

end for

//(Or just use the following table):

k[0.. 3] := { 0xd76aa478, 0xe8c7b756, 0x242070db, 0xc1bdcee3 }

k[4.. 7] := { 0xf57c0faf, 0x4787c62a, 0xa8304613, 0xfd469501 }

k[8..11] := { 0x698098d8, 0x8b44f7af, 0xffff5bb1, 0x895cd7be }

k[12..15] := { 0x6b901122, 0xfd987193, 0xa679438e, 0x49b40821 }

k[16..19] := { 0xf61e2562, 0xc040b340, 0x265e5a51, 0xe9b6c7aa }

k[20..23] := { 0xd62f105d, 0x02441453, 0xd8a1e681, 0xe7d3fbc8 }

k[24..27] := { 0x21e1cde6, 0xc33707d6, 0xf4d50d87, 0x455a14ed }

k[28..31] := { 0xa9e3e905, 0xfcefa3f8, 0x676f02d9, 0x8d2a4c8a }

k[32..35] := { 0xffffa3942, 0x8771f681, 0x6d9d6122, 0xfde5380c }

k[36..39] := { 0xa4bbee44, 0x4bdecfa9, 0xf6bb4b60, 0xbebfbc70 }

k[40..43] := { 0x289b7ec6, 0xeeaa127fa, 0xd4ef3085, 0x04881d05 }

k[44..47] := { 0xd9d4d039, 0xe6db99e5, 0x1fa27cf8, 0xc4ac5665 }

k[48..51] := { 0xf4292244, 0x432aff97, 0xab9423a7, 0xfc93a039 }

k[52..55] := { 0x655b59c3, 0x8f0ccc92, 0xffeff47d, 0x85845dd1 }

k[56..59] := { 0x6fa87e4f, 0xfe2ce6e0, 0xa3014314, 0x4e0811a1 }

k[60..63] := { 0xf7537e82, 0xbd3af235, 0x2ad7d2bb, 0xeb86d391 }

//Initialize VARs:

varint h0 := 0x67452301

varint h1 := 0xEFCDAB89

varint h2 := 0x98BADCFE

varint h3 := 0x10325476

//Pre-processing:

append "1" bit to message

append "0" bits until message length in bits $\equiv 448 \pmod{512}$

append length to message

/ bit (not byte) length of unpadded message as 64-bit little-endian integer */*

//Process the message in successive 512-bit chunks:

for each 512-bit chunk **of** message

break chunk into sixteen 32-bit little-endian words w[j], $0 \leq j \leq 15$

//Initialize hash value for this chunk:

varint a := h0

varint b := h1

varint c := h2

```

varint d := h3
//Main loop:
forfrom 0 to 63
if 0 ≤ i ≤ 15 then
f := (b and c) or ((not b) and d)
g := i
else if 16 ≤ i ≤ 31
f := (d and b) or ((not d) and c)
g := (5×i + 1) mod 16
else if 32 ≤ i ≤ 47
f := b xor c xor d
g := (3×i + 5) mod 16
else if 48 ≤ i ≤ 63
f := c xor (b or (not d))
g := (7×i) mod 16
temp := d
d := c
c := b
b := b + leftrotate((a + f + k[i] + w[g]) , r[i])
a := temp
end for
//Add this chunk's hash to result so far:
h0 := h0 + a
h1 := h1 + b
h2 := h2 + c
h3 := h3 + d
end for
varchar digest[16] := h0 append h1 append h2 append h3 //(expressed as little-endian)
//leftrotate function definition
leftrotate (x, c)
return (x << c) or (x >> (32-c));

```

Note: Instead of the formulation from the original [RFC 1321](#) shown, the following may be used for improved efficiency (useful if assembly language is being used - otherwise, the compiler will generally optimize the above code. Since each computation is dependent on another in these formulations, this is often slower than the above method where the nand/and can be parallelised):

```

(0 ≤ i ≤ 15): f := d xor (b and (c xor d))
(16 ≤ i ≤ 31): f := c xor (d and (b xor c))

```

Source: <http://en.wikipedia.org/wiki/MD5>